

# INSTRUCTION MANUAL

**IGT8** RED

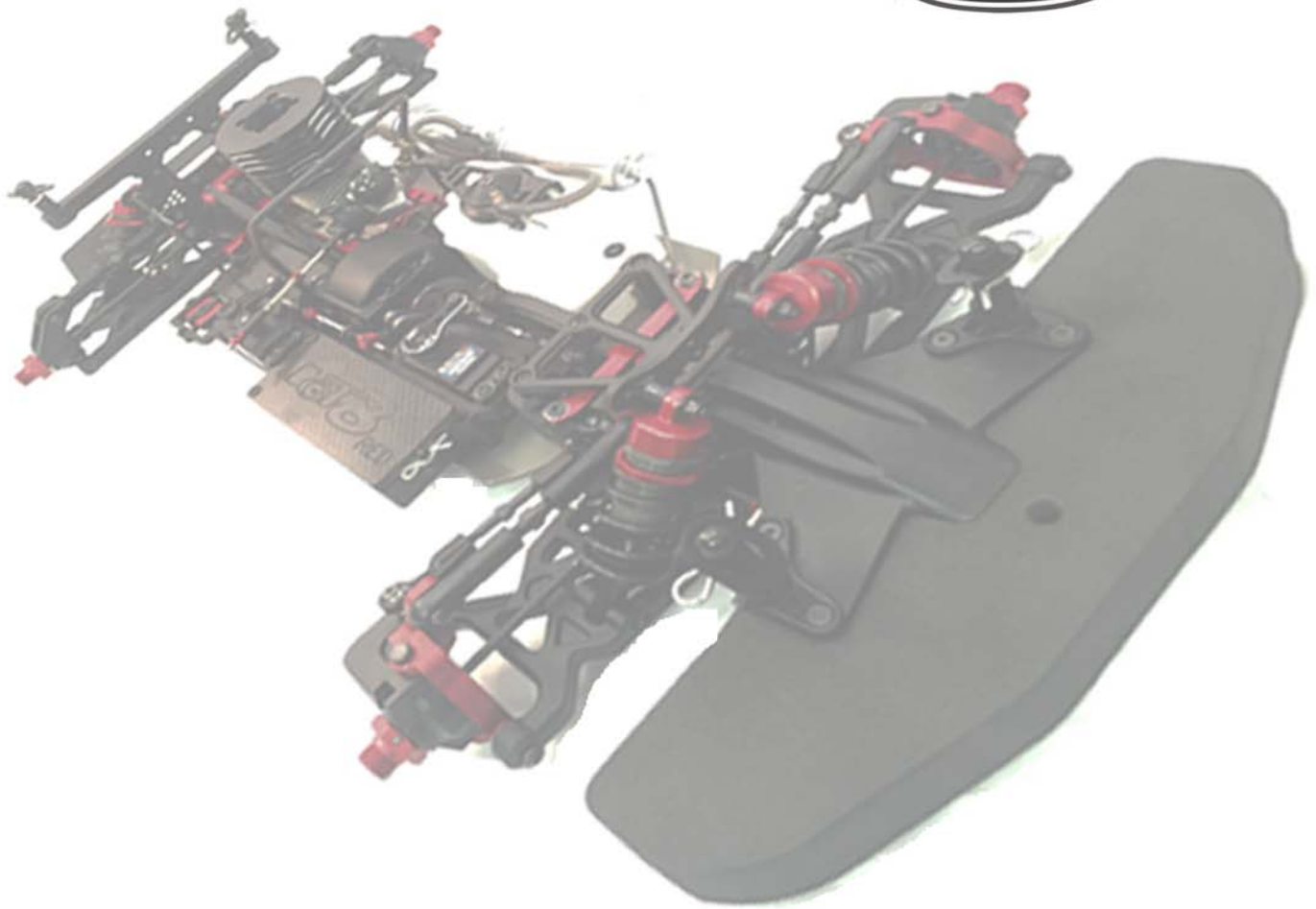

[www.igt8.com](http://www.igt8.com)

For any additional questions, please send us an email to: [info@igt8.com](mailto:info@igt8.com)

# OVERVIEW

## Components



IGT8 Stickers



USB Manual

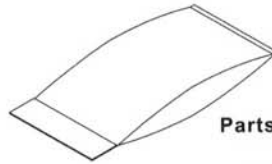

Parts Bag

## TOOLS NOT INCLUDED IN THE KIT



Body Reamer



Screw Cement



Instant Cement

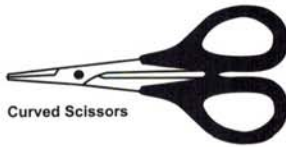

Curved Scissors



Cutter



Gear Grease



Needle Nosed Pliers



Craft Knife



Precision Caliper

## Equipment Needed

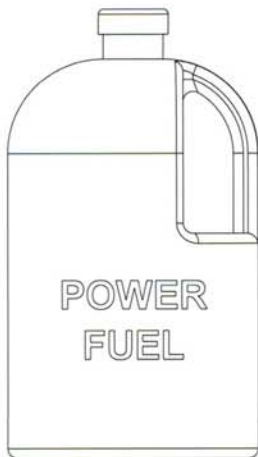

Glow Fuel



Fuel Bottle



UM-3 Batteries (8pcs)



Glow Plug

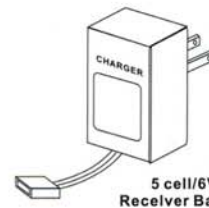

5 cell/6Volt Ni-Mh Receiver Battery Charger



Glow Igniter



5 cell/6Volt Ni-Mh Receiver Battery

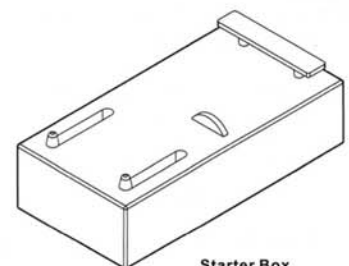

Starter Box (For not pullstat engine)

# IMPORTANT-READ THIS BEFORE RUNNING

Running nitro kit is fun and easy, but to make this a safe and good experience you must observe a few rules. This kit is extremely fast, easily over 65KPH, and can seriously injure someone if you are not careful.

## 1. Where to run car?

- ⊙ Any running area you choose must be dry. Do not run car near any water or wet dirt.
- ⊙ Do not run on public streets. It is very easy to have the car run over or be damaged by hitting the curb.
- ⊙ Do not operate the car in tight confined places. The car is very fast and will easily hit something.
- ⊙ Do not run near people or animals. The car is very fast and could easily hit someone if you are not an expert driver.
- ⊙ Due to noise, you will want to consider the surrounding area when operating the car.
- ⊙ Do not operate the car at night. You will not be able to drive it safely.
- ⊙ Do not operate the car indoors. Engine exhaust fumes are dangerous.

## 2. Glow Fuel

- ⊙ Glow fuel is poisonous!
- ⊙ Glow fuel is flammable!
- ⊙ Do not leave in fuel bottle with lid off at any time.
- ⊙ Do use any fuel other than glow fuel in this engine.

## 3. First Time Starting the Engine

### Caution!

**When starting the engine make sure the following is observed.**

- ⊙ Set engine Master needle to 3 turns (rich setting)
- ⊙ Do not do this alone, get an experienced friend to help for the first time.
- ⊙ Fill fuel tank, try not to spill fuel. Do not spill fuel on receiver.
- ⊙ Hold car off the ground, so it will not runaway when it first starts.
- ⊙ Turn on the radio and check the linkage before starting engine.
- ⊙ Turn on car receiver battery switch.
- ⊙ Always have an air filter on the carburetor to keep dirt out.

## 4. Emergency Engine Stopping

- ⊙ Remove air filter and cover carb. intake.
- ⊙ Squeeze fuel line and hold until engine stops.
- ⊙ With a rag, cover exhaust outlet.

## 5. Storing Car After Running

- ⊙ Remove fuel from tank and fuel lines
- ⊙ Turn off radio in the car
- ⊙ Put a few drops of after run in the engine to keep it from rusting.
- ⊙ Clear oil and dirt from chassis with a degreaser.

## 6. Precautions













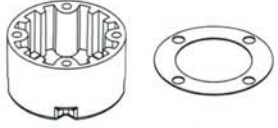



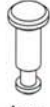





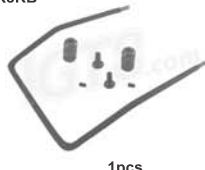
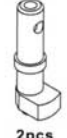

- ⊙ This kit is not a toy. Always run car with a second person as a spotter and pitman.
- ⊙ Hot Parts-The pipe, manifold, engine and head are very hot and will cause burns.
- ⊙ Rotating Parts-Keep hands away from the drive train, wheels, and engine when engine is running.
- ⊙ Radio-Check battery life before running the car. The radio does not have full control of the car with steering and/or throttle/brake, do not run until corrected. Failure to correct this will result in possible injury and damage to the car or property. We strongly recommend using a Failsafe.
- ⊙ Glow fuel-Do not leave the glow fuel unattended with the lid off. Fuel contains Methanol and Nitro Methane and is flammable and poisonous.

**Store fuel in cool ventilated location.**





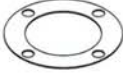





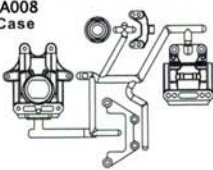
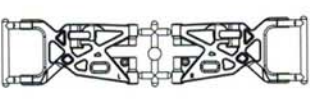

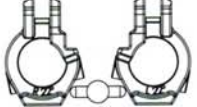
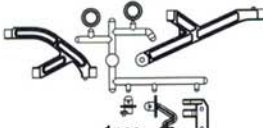
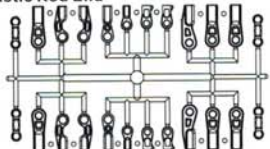
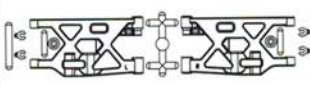
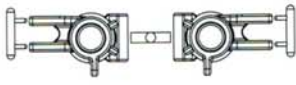

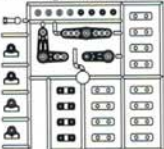
**Refer to the glow fuel label for additional precautions.**

- ⊙ Fuel tank in the car-Never store fuel in car tank, it will ruin the engine if left in tank.
- ⊙ Always turn off the car BEFORE turning off the radio.
- ⊙ **DAMAGE DUE CAR RUN AWAY IS NOT A WARRANTY ISSUE .**

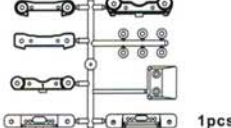
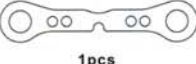
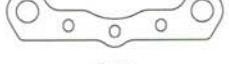

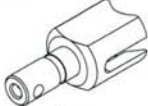
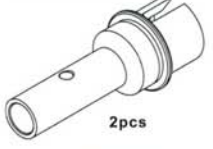
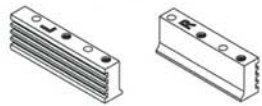

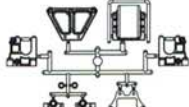
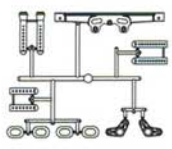

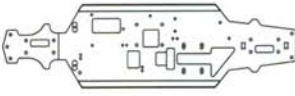



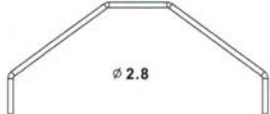
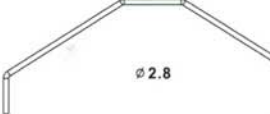



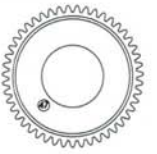

# PARTS REFERENCE

<p>IGT8HF004 Diff. Gear 10Tx4, 20Tx2, 0.15mmx8</p>  <p>2pcs      4pcs      8pcs</p>	<p>IGT8HD040 Front wheel CVD Shaft Set, 107.5mm</p>  <p>2pcs      2pcs      2pcs</p>	<p>IGT8HD04A Front Wheel CVD Shaft, 107.5mm</p>  <p>2pcs</p>	<p>IGT8HF001 Diff. Case (F&amp;R)</p>  <p>1pcs      1pcs</p>
<p>IGT800H05A Rear Wheel CVD Shaft, 105mm</p>  <p>2pcs</p>	<p>IGT8HF071 Drive Shaft Insert / 2.5 x 12.8 Pin</p>  <p>4pcs      4pcs</p>	<p>IGT8HD004 CVD Wheel Axle</p>  <p>2pcs</p>	<p>IGT8HF019 3.5 x 45.8 Rear Upright Shaft</p>  <p>2pcs</p>
<p>IGT8HF040 Steering King Pin</p>  <p>4pcs</p>	<p>IGT8HF042 Front Arm Bushing</p>  <p>4pcs</p>	<p>IGT8HF024 Servo Saver Post</p>  <p>2pcs</p>	<p>IGT8HF014 Alum. Servo Saver Tube</p>  <p>2pcs</p>
<p>IGT8HF050 Fuel Tank 150cc</p>  <p>1pcs</p>	<p>IGT800H10 Servo Saver Adjuster, 12 x 1.7 O-Ring</p>  <p>1pcs      1pcs</p>	<p>IGT8H00H18 Servo Saver Connecting Plate, BType</p>  <p>1pcs</p>	<p>IGT8HF029 Servo Saver Screw</p>  <p>2pcs</p>
<p>IGT8HF030 Servo Saver Bushing</p>  <p>2pcs</p>	<p>IGT8X3RB</p>  <p>1pcs</p>	<p>IGT8HF018 Brake Cam</p>  <p>2pcs</p>	<p>IGT8HF072 Brake Pad Screw</p>  <p>4pcs</p>
<p>IGT8HF054 Brake Rod Spring</p>  <p>2pcs</p>	<p>IGT8HF031 7x8.5mm Ball &amp; Socket</p>  <p>4pcs</p>	<p>IGT8HF033 7x12mm Ball &amp; Socket</p>  <p>4pcs</p>	<p>IGT8HF073 Hex 4mm Ball &amp; Socket</p>  <p>2pcs</p>
<p>IGT8HF036 2.5x11.8 Pins</p>  <p>10pcs</p>	<p>IGT8HF070 2.5x12.8 Pin</p>  <p>10pcs</p>	<p>IGT8HF055 Brake Linkage Rod 1.8 x 95mm</p>  <p>1pcs</p>	<p>IGT8HF035 Diff Gasket 31x20x0.3</p>  <p>3pcs</p>
<p>IGT8HF074 4x8mm Engine Mount Screw</p>  <p>4pcs</p>	<p>IGT8HF046 4x10mm Set Screw, Round Head</p>  <p>4pcs</p>		

# PARTS REFERENCE

<p><b>IGT8HA008</b> Gear Case</p>  <p>1pcs</p>	<p><b>IGT8HA004</b> Front Lower Arms L&amp;R</p>  <p>1pcs</p>	<p><b>IGT8HA013</b> Steering Knuckle Arm L,R</p>  <p>1pcs</p>	<p><b>IGT8HA015</b> Front C Hub L,R</p>  <p>1pcs</p>					
<p><b>IGT8HA011</b> Body Post/Center Brace</p>  <p>1pcs</p>	<p><b>IGT8HA007</b> Plastic Rod End</p>  <p>1pcs</p>	<p><b>IGT8HA005</b> Rear Lower Arms L&amp;R</p>  <p>1pcs</p>	<p><b>IGT8HA014</b> Rear Hub Carrier L&amp;R</p>  <p>1pcs</p>					
<p><b>IGT8HA009</b> Receiver/Battery Box</p>  <p>1pcs</p>	<p><b>IGT8HA010</b> Throttle/Steering Level Set</p>  <p>1pcs</p>	<p><b>IGT8HE006</b> 8x14 Ball Bearing</p>  <p>4pcs</p>	<p><b>IGT8HE001</b> 13x20 Ball Bearing</p>  <p>4pcs</p>					
<table border="0"> <tbody> <tr> <td><b>IGT8HF075</b> Screw Bag</td> <td> <ul style="list-style-type: none"> <li>3x5 10pcs</li> <li>3x8 2pcs</li> <li>3x10 8pcs</li> <li>3x12 8pcs</li> </ul> </td> <td> <ul style="list-style-type: none"> <li>3x15 12pcs</li> <li>3x18 10pcs</li> <li>3x20 2pcs</li> <li>3x22 2pcs</li> </ul> </td> <td> <ul style="list-style-type: none"> <li>3x25 2pcs</li> <li>3x35 2pcs</li> <li>4x15 1pcs</li> <li>4x18 4pcs</li> </ul> </td> <td> <ul style="list-style-type: none"> <li>3x8 10pcs</li> <li>3x10 7pcs</li> <li>3x15 6pcs</li> <li>3x16 2pcs</li> </ul> </td> </tr> </tbody> </table>				<b>IGT8HF075</b> Screw Bag	<ul style="list-style-type: none"> <li>3x5 10pcs</li> <li>3x8 2pcs</li> <li>3x10 8pcs</li> <li>3x12 8pcs</li> </ul>	<ul style="list-style-type: none"> <li>3x15 12pcs</li> <li>3x18 10pcs</li> <li>3x20 2pcs</li> <li>3x22 2pcs</li> </ul>	<ul style="list-style-type: none"> <li>3x25 2pcs</li> <li>3x35 2pcs</li> <li>4x15 1pcs</li> <li>4x18 4pcs</li> </ul>	<ul style="list-style-type: none"> <li>3x8 10pcs</li> <li>3x10 7pcs</li> <li>3x15 6pcs</li> <li>3x16 2pcs</li> </ul>
<b>IGT8HF075</b> Screw Bag	<ul style="list-style-type: none"> <li>3x5 10pcs</li> <li>3x8 2pcs</li> <li>3x10 8pcs</li> <li>3x12 8pcs</li> </ul>	<ul style="list-style-type: none"> <li>3x15 12pcs</li> <li>3x18 10pcs</li> <li>3x20 2pcs</li> <li>3x22 2pcs</li> </ul>	<ul style="list-style-type: none"> <li>3x25 2pcs</li> <li>3x35 2pcs</li> <li>4x15 1pcs</li> <li>4x18 4pcs</li> </ul>	<ul style="list-style-type: none"> <li>3x8 10pcs</li> <li>3x10 7pcs</li> <li>3x15 6pcs</li> <li>3x16 2pcs</li> </ul>				
<ul style="list-style-type: none"> <li>3x35 4pcs</li> <li>4x12 8pcs</li> <li>4x16 4pcs</li> </ul>	<p><b>IGT8X3CV</b> Carbon Fiber Radio Tray Cover</p> 	<p><b>IGT8HE007</b> Ball Bearing Bag</p> <table border="0"> <tbody> <tr> <td>5x11x4 4pcs</td> <td>8x14x4 4pcs</td> <td>8x16x5 6pcs</td> <td>13x20x4 4pcs</td> </tr> </tbody> </table>		5x11x4 4pcs	8x14x4 4pcs	8x16x5 6pcs	13x20x4 4pcs	
5x11x4 4pcs	8x14x4 4pcs	8x16x5 6pcs	13x20x4 4pcs					
<p><b>IGT8HF069</b> Plastic Suspension Bracket Part</p>  <p>1pcs</p>	<p><b>IGT8HF076</b> Suspension Bracket Plate (Red)</p>  <p>1pcs</p> <p>*Need Use In IGT8HF069</p>	<p><b>IGT8HF077</b> Suspension Bracket Plate (Red)</p>  <p>1pcs</p> <p>*Need Use In IGT8HF069</p>	<p><b>IGT8HD001</b> 98mm Drive Shaft</p>  <p>2pcs</p>					
<p><b>IGT8HF005</b> Diff. Cap Joint</p>  <p>2pcs</p>	<p><b>IGT8HD003</b> Rear Wheel Axle Shaft</p>  <p>2pcs</p>	<p><b>IGT800H20</b> Engine Mount L&amp;R</p>  <p>1pcs 1pcs</p>	<p><b>IGT8HA001</b> Front &amp; Rear Bumper</p>  <p>1pcs</p>					
<p><b>IGT8HA003</b> Center Diff Mount</p>  <p>1pcs</p>	<p><b>IGT8HA002</b> Body Mount</p>  <p>1pcs</p>	<p><b>IGT800F07 &amp; IGT800F08</b> Front &amp; Rear Shock Tower</p>  <p>1pcs 1pcs</p>	<p><b>IGT8X3CHS</b> 6061-3mm Chassis-Nitro</p>  <p>1pcs</p>					

# PARTS REFERENCE

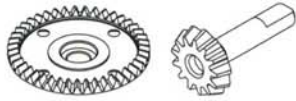
<p><b>X3GTPROUSB1</b> Instruction Manual (USB)</p>  <p>USB Manual</p>	<p><b>IGT8HF078</b> Front Anti-roll Bar 2.8mm, Black</p>  <p>∅ 2.8</p> <p>1pcs</p>	<p><b>IGT8HF026</b> Rear Anti-roll Bar 2.8mm, Black</p>  <p>∅ 2.8</p> <p>1pcs</p>	<p><b>IGT8HD002</b> 97mm &amp; 104mm Drive Shaft</p>  <p>1Set</p>
<p><b>IGT8HB049</b> 49T 1st Spur Gear</p>  <p>1pcs</p>	<p><b>IGT8HB048</b> 48T 1st Spur Gear</p>  <p>1pcs</p>	<p><b>IGT8HB047</b> 47T 1st Spur Gear</p>  <p>1pcs</p>	<p><b>IGT8HB046</b> 46T 2st Spur Gear</p>  <p>1pcs</p>
<p><b>IGT8HB045</b> 45T 2st Spur Gear</p>  <p>1pcs</p>	<p><b>IGT8HB044</b> 44T 2st Spur Gear</p>  <p>1pcs</p>	<p> </p>	<p><b>IGT8HC016</b> 16T 1st Clutch Gear</p>  <p>1pcs</p>
<p><b>IGT8HC017</b> 17T 1st Clutch Gear</p>  <p>1pcs</p>	<p><b>IGT8HC019</b> 19T 2st Clutch Gear</p>  <p>1pcs</p>	<p><b>IGT8HC020</b> 20T 2st Clutch Gear</p>  <p>1pcs</p>	<p><b>IGT8HC021</b> 21T 2st Clutch Gear</p>  <p>1pcs</p>
<p><b>IGT8HF009</b> 16mm GT Shock Spring, Medium (Black)</p> <p>2.3x35x5.25T- 4pcs</p> 	<p><b>IGT8HC014</b> 14T 1st Clutch Gear</p>  <p>1pcs</p>	<p><b>IGT8HC018</b> 18T 2st Clutch Gear</p>  <p>1pcs</p>	<p><b>IGT8HF002 &amp; IGT8HF003</b> Spiral Bevel Gear 43T&amp;13T</p>  <p>1pcs      1pcs</p>
<p> </p>	<p> </p>	<p> </p>	<p> </p>
<p> </p>	<p> </p>	<p> </p>	<p> </p>
<p> </p>	<p> </p>	<p> </p>	<p> </p>

# OPTION PARTS REFERENCE

**IGT800H01** OPT  
Diff. Cap Joint (Lightweight)





2pcs

**IGT800H07** OPT  
Chassis Brace (Front/Rear)



1pcs      1pcs

3x12      3x10      M3 Nut

1pcs      4pcs      5pcs

**IGT800H04** OPT  
Alim. Diff Cross Pin(Hard-Coated)



6pcs

**IGT8HF017** OPT  
Brake Pad (For:Nitro)



2pcs

**IGT8HG001** OPT  
Center CVD Cap Joint



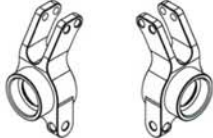

1pcs

**IGT800H19** OPT  
Alum. Rear Hub Carrier L,R



1pcs      1pcs

4mm      8x16x5      13x20x4



4pcs      2pcs      2pcs

**IGT800H09** OPT  
Alum. Chassis Brace Mount



1pcs

4x20      M4 Nut

1pcs      1pcs

**IGT800H06** OPT  
Screw Type Arms Shaft, 3.5mm



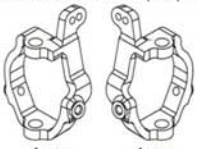

2pcs

**IGT800H14** OPT  
Alum. CNC C Hub (10") L,R



1pcs      1pcs

3x18      M3 Nut



2pcs      2pcs

**IGT8HG002** OPT  
Alum. CNC C Hub (12") L,R

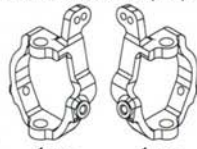

1pcs      1pcs

3x18      M3 Nut

2pcs      2pcs

**IGT800F10** OPT  
One-piece bulkhead with CNC insert and bearings

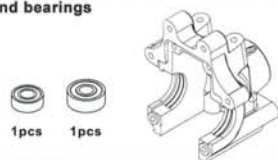

1pcs      1pcs

**IGT8HG003** OPT  
Spiral Bevel Gear 42T&14T



1pcs      1pcs

**IGT8HG004** OPT  
Center CVD Shaft Set, Front, 95mm

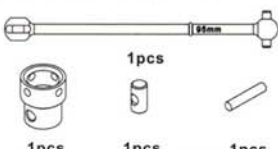

1pcs      1pcs      1pcs

**IGT8HG04A** OPT  
Center CVD Shaft, Front ,95mm



1pcs

**IGT8HF079** OPT  
Rear Anti-Roll Bar 2.5mm,Nnickel-Plating

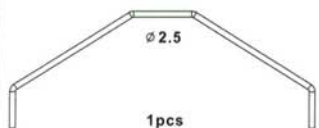

∅ 2.5

1pcs

**IGT800H05** OPT  
Rear Wheel CVD Shaft Set, 105mm

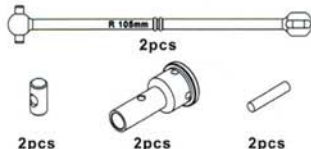

2pcs      2pcs      2pcs

**IGT8HF080** OPT  
SP Disk Break Set (Front)



**IGT8HF081** OPT  
SP Disk Break Set (Rear)



**IGT8HF015** OPT  
CNC Brake Disk (Front)



1pcs

**IGT8HF016** OPT  
CNC Brake Disk (Rear)



1pcs

**IGT8HF080** OPT  
SP Disk Break Set (Front)



**IGT8HF081** OPT  
SP Disk Break Set (Rear)



**IGT8HF015** OPT  
CNC Brake Disk (Front)



1pcs

**IGT8HF016** OPT  
CNC Brake Disk (Rear)



1pcs

**IGT8HF080** OPT  
SP Disk Break Set (Front)



**IGT8HF081** OPT  
SP Disk Break Set (Rear)



## SYMBOLS USED THROUGHOUT THE INSTRUCTION MANUAL



Parts Bag Used



Degrease With Motor Spray



Do Not Over Tighten



Tighten



Ensure Free Movement



Contact Adhesive



Apply Screw Cement



Apply Oil



Apply Lubricant



True-To-Scale



Time



Pay attention here

# 1 ASSEMBLY OF THE FRONT AND REAR DIFF.

**BAG 1**

Build two differentials for front and rear.

**Step 1**

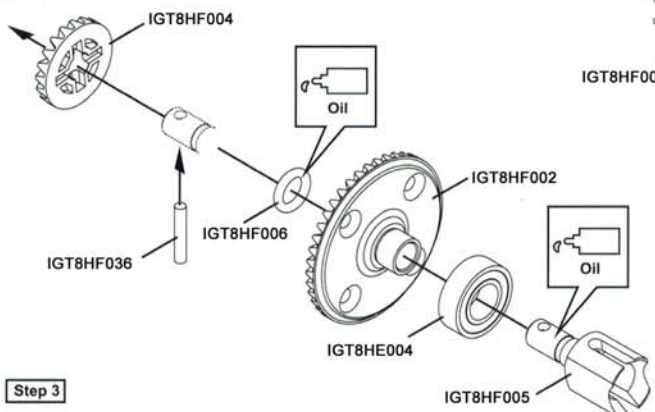

**Step 2**

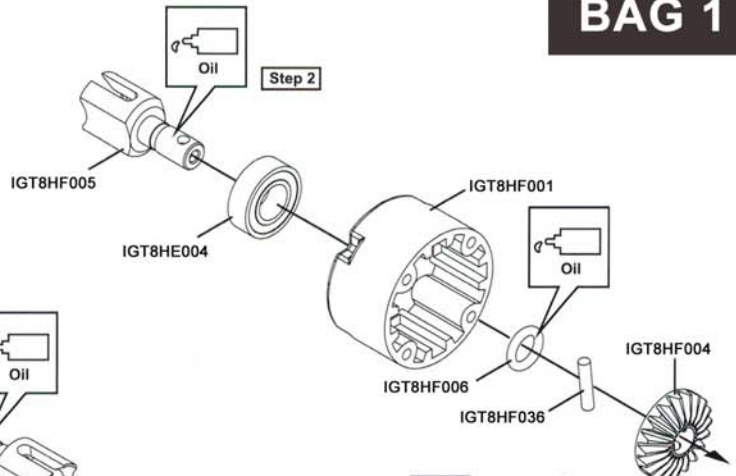

**Step 3**

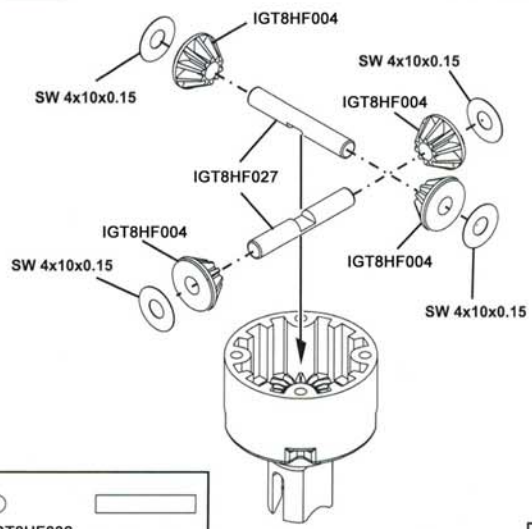

**Step 4**



**Step 5**

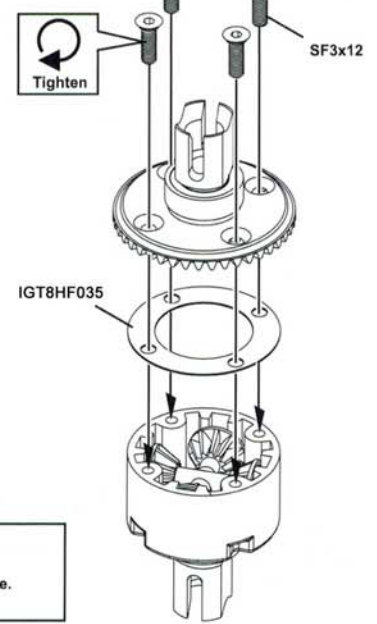

- Use diff oil 100,000 for front and 5,000 for rear.
- Use White Oil pen mark front diff. case and rear diff. case.

- IGT8HF036  
2.5x11.8mm Pin .....x4
- IGT8HF006  
P6 O-Ring .....x4
- IGT8HE004  
8x16x5mm  
Ball Bearing .....x4
- SW 4x10x0.15  
4x10x0.15mm  
Washer .....x8
- IGT8HF027  
4mm Cross Pin .....x4
- SF3x12mm  
Flat Head Hex Screw .....x8

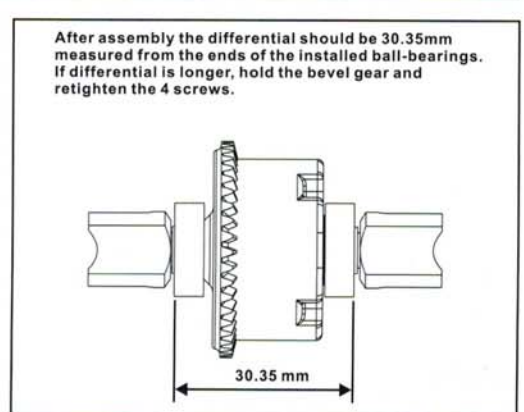
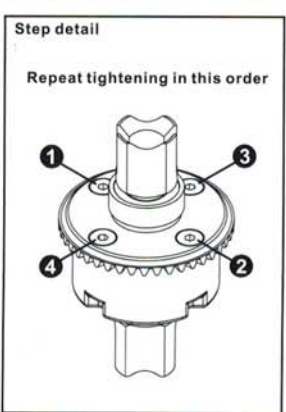
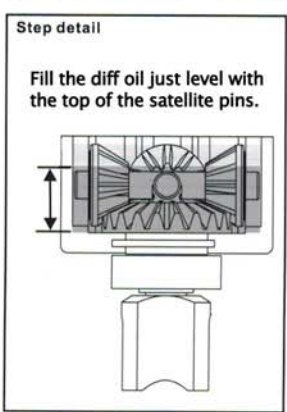
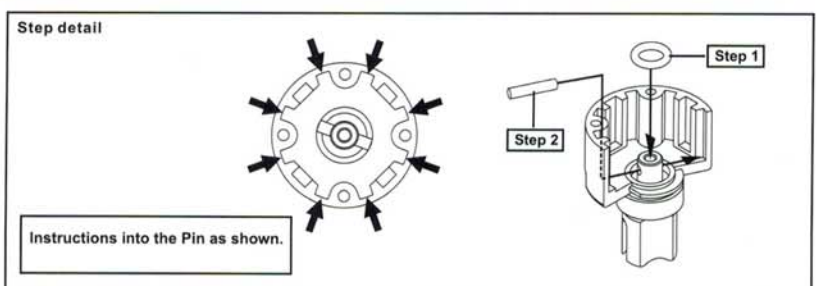
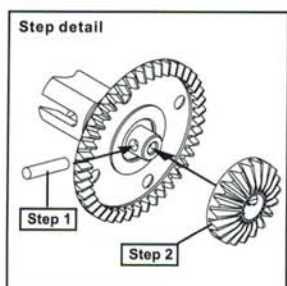



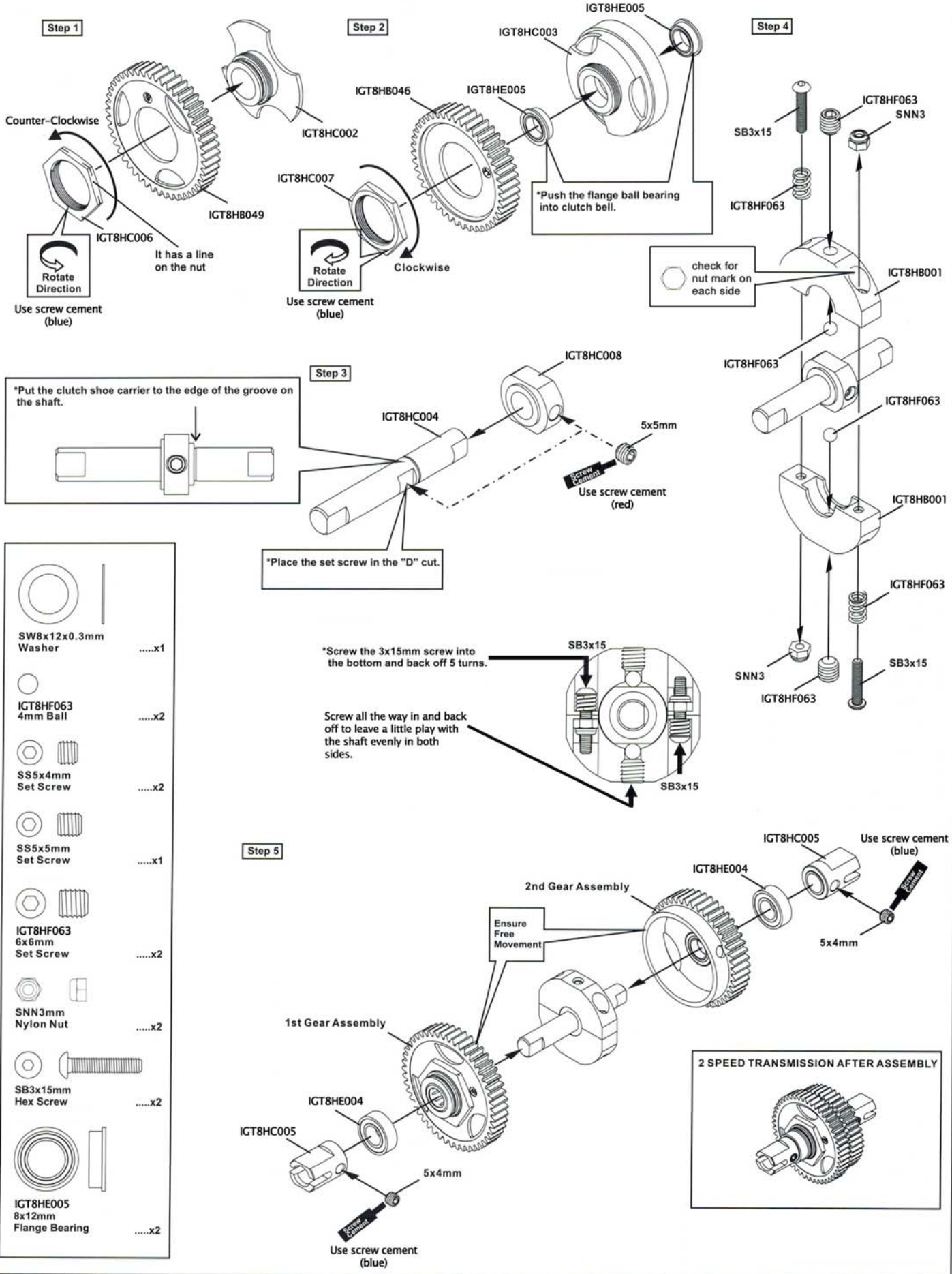

Step 1

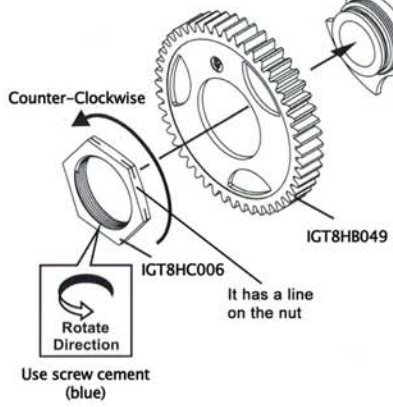

Step 2

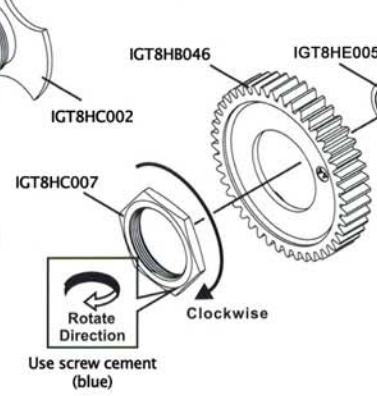

Step 4

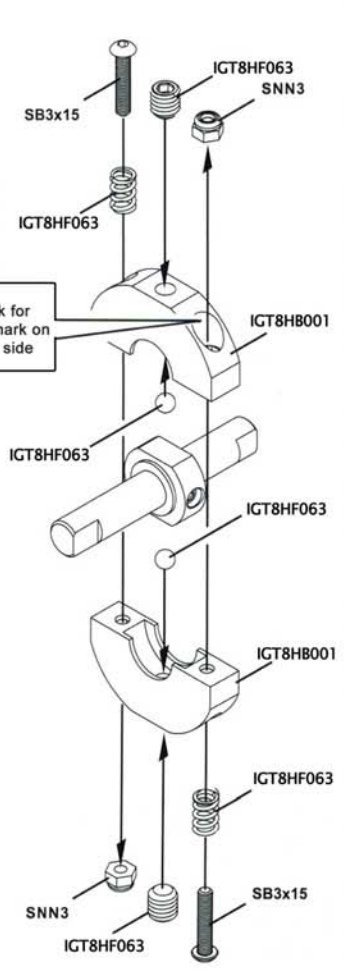

Step 3

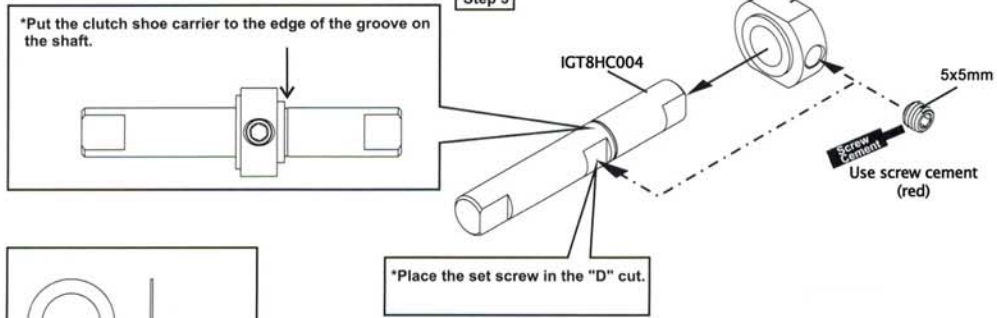

\*Screw the 3x15mm screw into the bottom and back off 5 turns.

Screw all the way in and back off to leave a little play with the shaft evenly in both sides.

Step 5

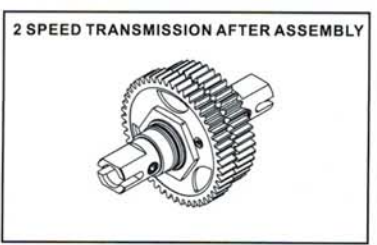
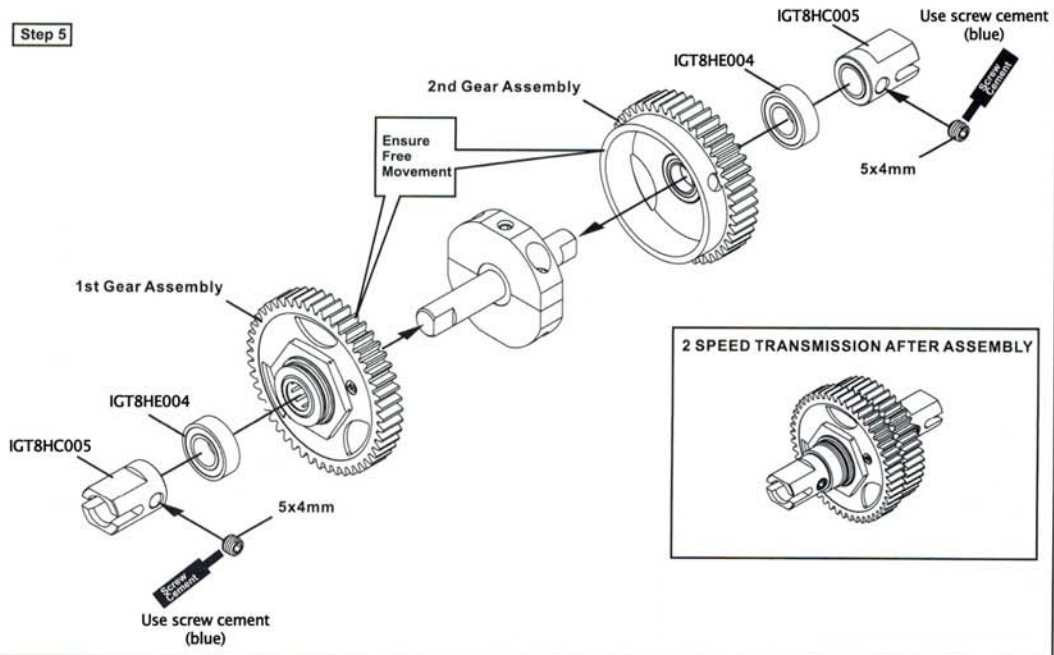

- SW8x12x0.3mm Washer .....x1
- IGT8HF063 4mm Ball .....x2
- SS5x4mm Set Screw .....x2
- SS5x5mm Set Screw .....x1
- IGT8HF063 6x6mm Set Screw .....x2
- SNN3mm Nylon Nut .....x2
- SB3x15mm Hex Screw .....x2
- IGT8HE005 8x12mm Flange Bearing .....x2

### 3 ASSEMBLY OF THE CENTER DIFF. MOUNT

**BAG 5**

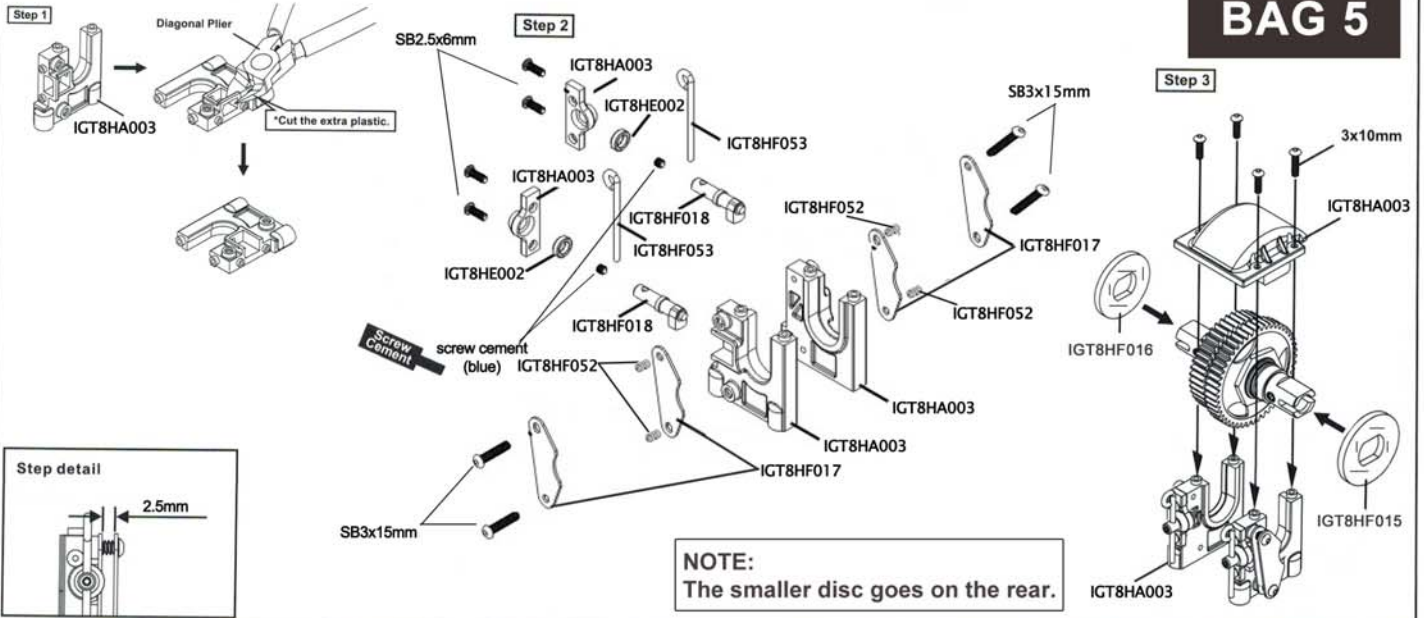

### 4 ASSEMBLY OF THE FRONT GEAR CASE

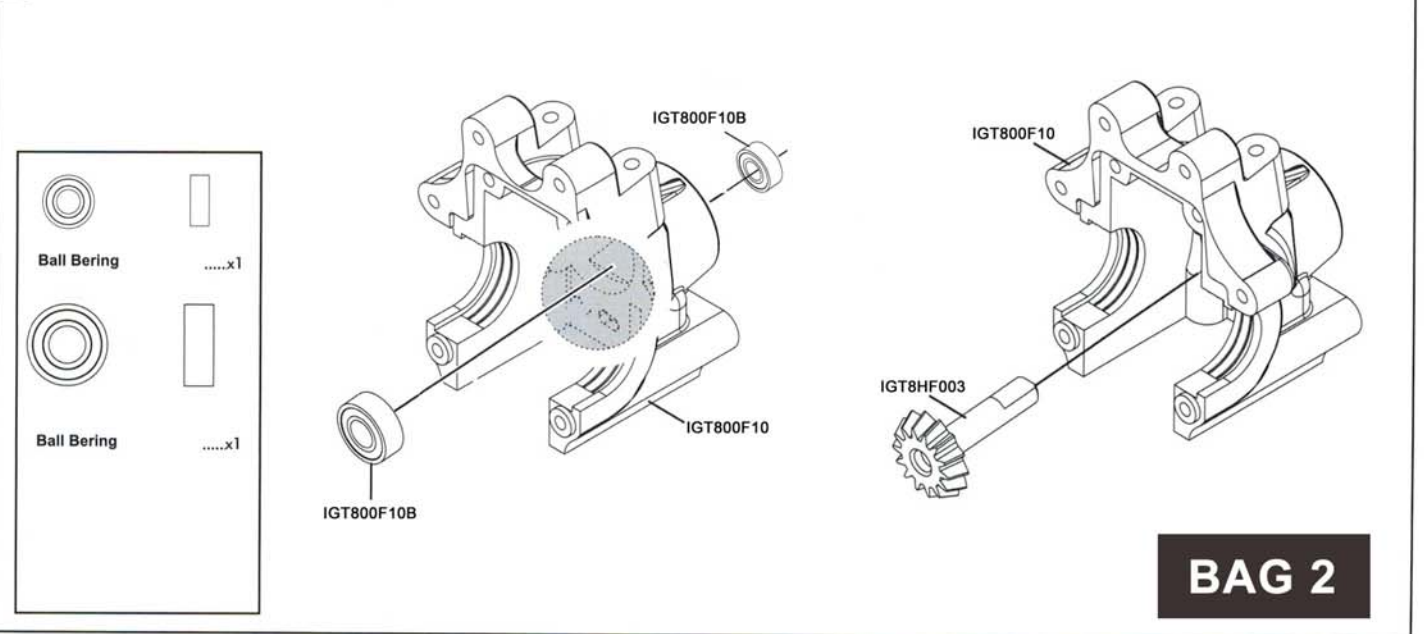

### 5 ASSEMBLY OF THE FRONT DIFFERENTIAL INTO GEAR CASE

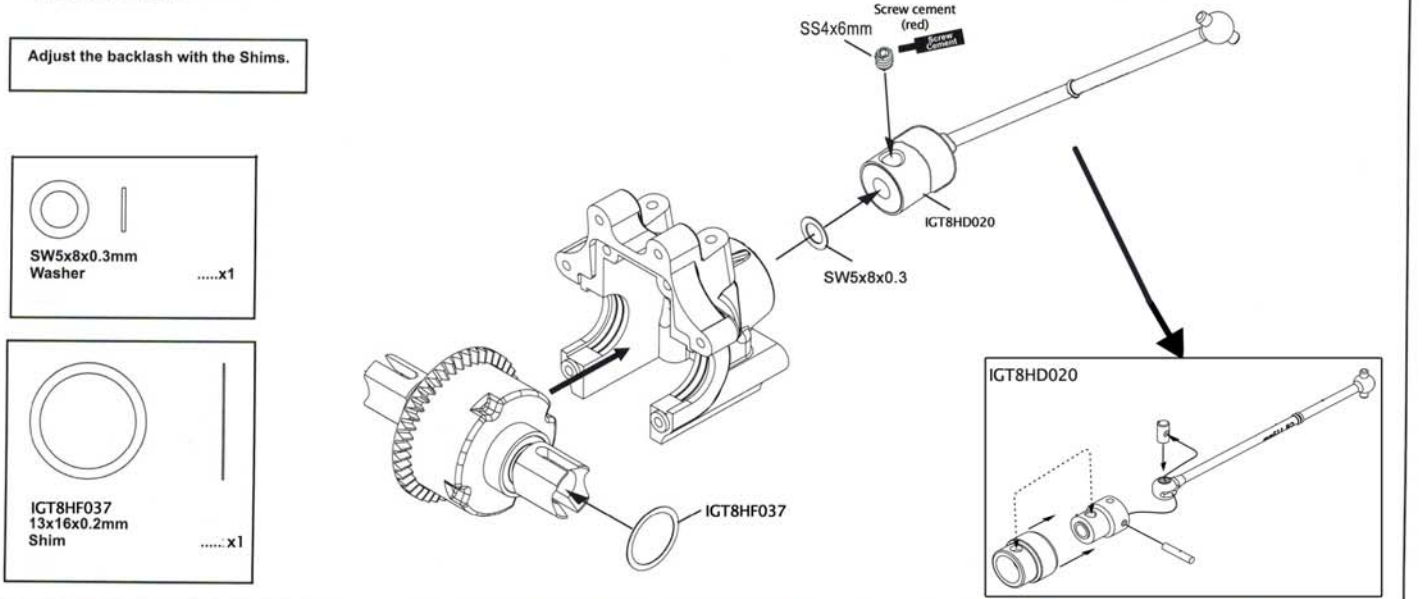

**6 ASSEMBLY OF THE FRONT DIFFERENTIAL INTO GEAR CASE**

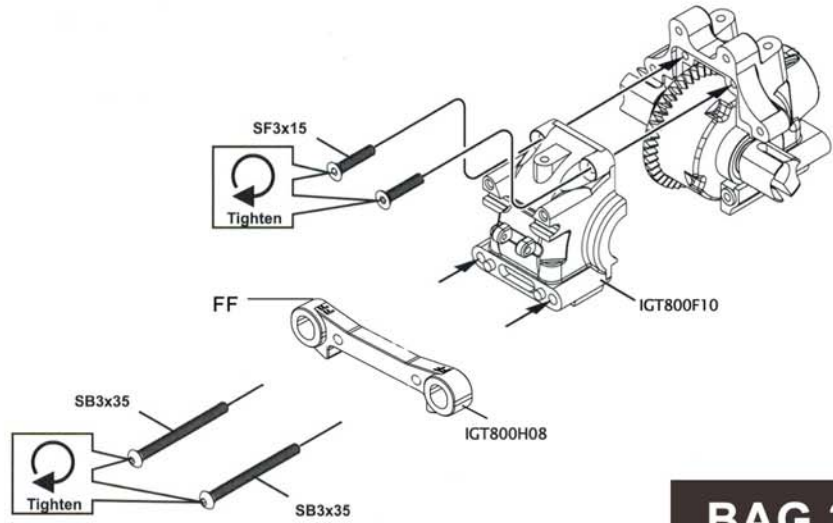
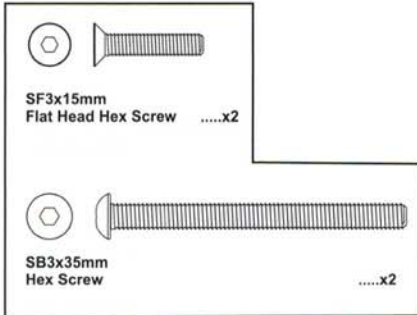

**BAG 2**

**7 ASSEMBLY OF THE FRONT SHOCK STAY**

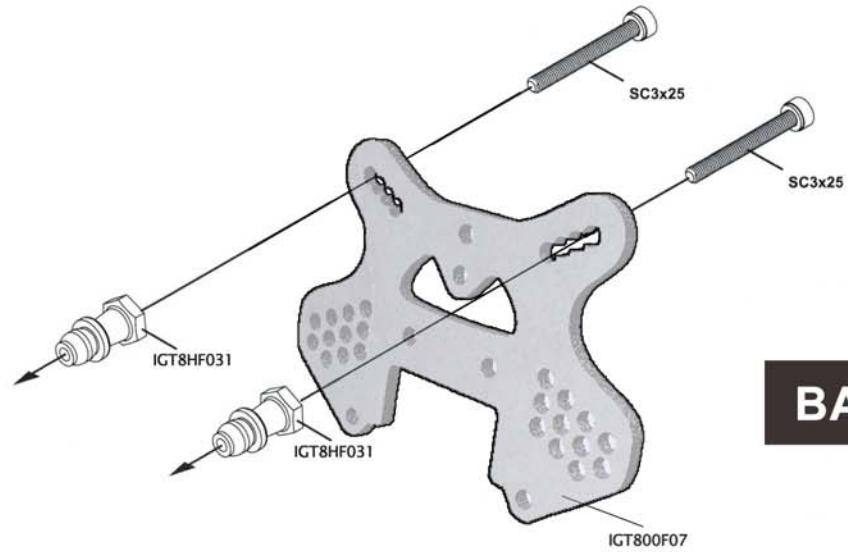
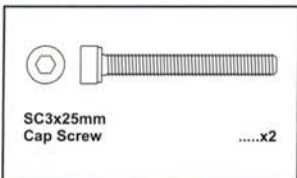

**BAG 2**

**8 ASSEMBLY OF THE FRONT SHOCK STAY ONTO GEAR CASE**

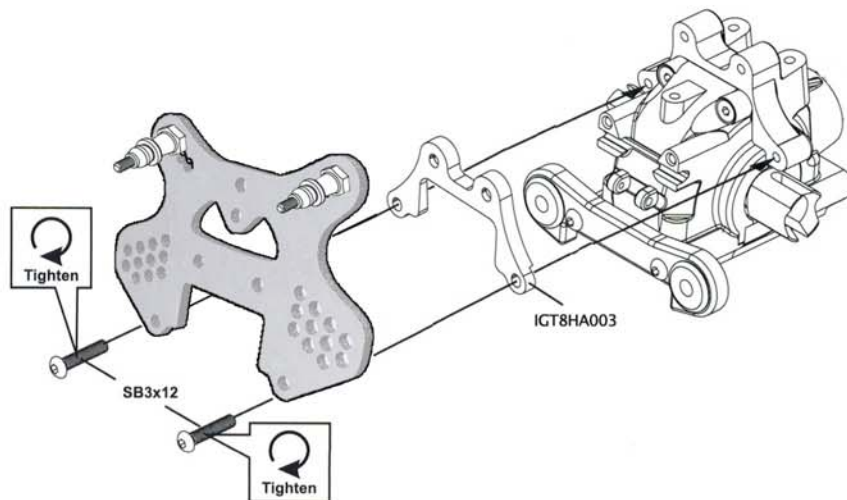
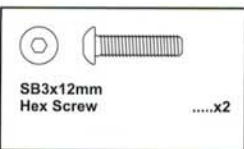

## 9 ASSEMBLY OF THE SHOCK EXTENSIONS

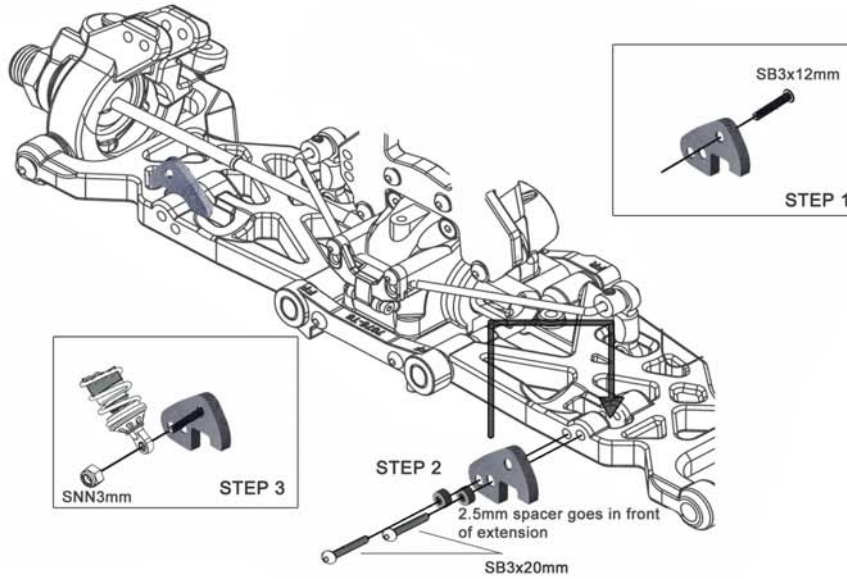

## 10 ASSEMBLY OF THE FRONT LOWER ARMS

Assemble both right and left sides.

Step detail

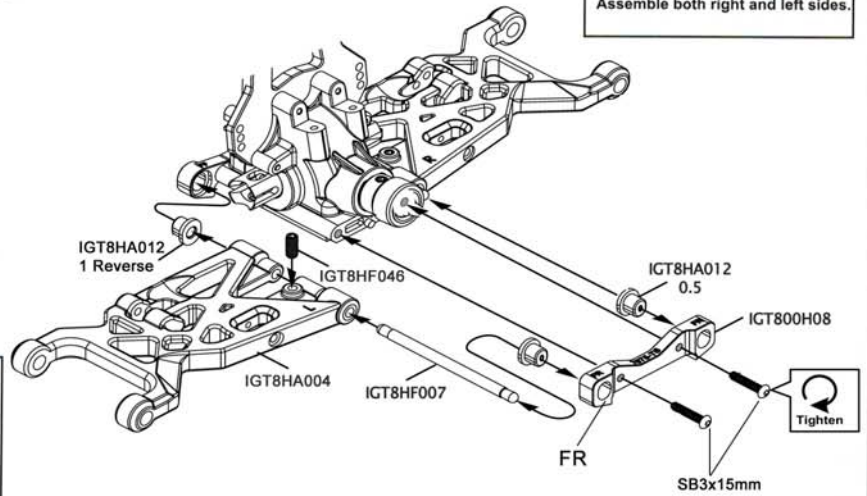

IGT8HF046  
4x10mm  
Round Head Set Screw .....x2



**BAG 2**

## 11 ASSEMBLY OF THE FRONT STABILIZER ROD

**BAG 2**

Step detail

Ensure Free Movement



Step detail

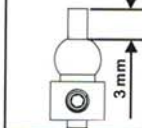

SB2.5x8mm  
Hex Screw .....x2

SC2x12mm  
Cap Screw .....x1

SB3x18mm  
Hex Screw .....x2

SS3x3mm  
Set Screw .....x4

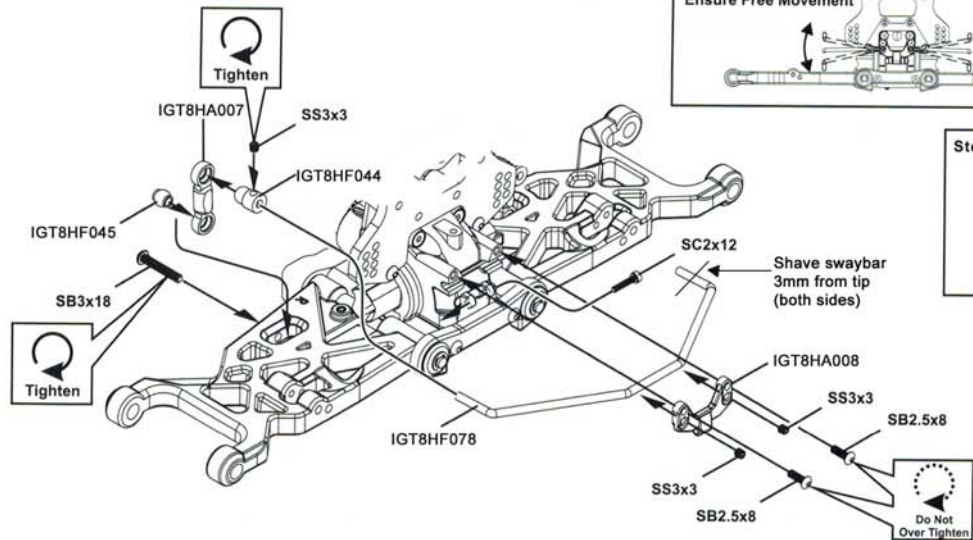

## 12 ASSEMBLY OF THE FRONT KNUCKLE ARMS

**BAG 2**

**LEFT SIDE**

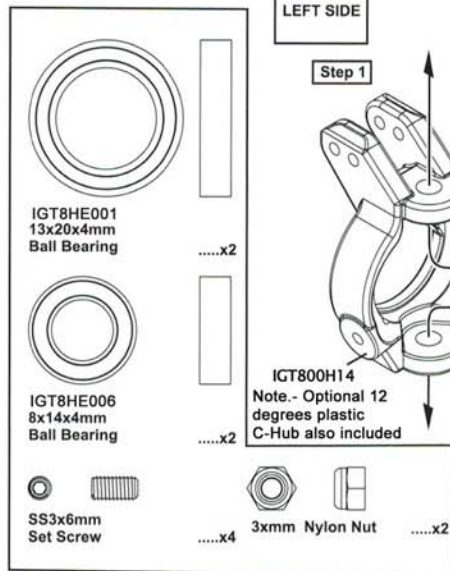

IGT8HE001  
13x20x4mm  
Ball Bearing .....x2

IGT8HE006  
8x14x4mm  
Ball Bearing .....x2

SS3x6mm  
Set Screw .....x4

3xmm Nylon Nut .....x2

**LEFT SIDE**

**Step 1**

**Step 2**

**Step 3**

IGT800H14  
Note - Optional 12  
degrees plastic  
C-Hub also included

Note - Kit comes with 2 caster options:  
12 degree plastic (shown) and  
10 degree aluminum

**Step detail**

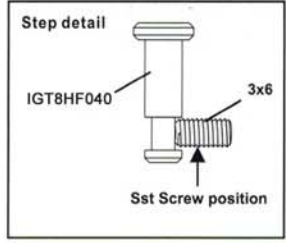

IGT8HF040

3x6

Sst Screw position

Assemble both right and left sides.

## 13 ASSEMBLY OF THE FRONT CVD INTO KNUCKLE ARMS

**BAG 2**

**LEFT SIDE**

Assemble both right and left side.

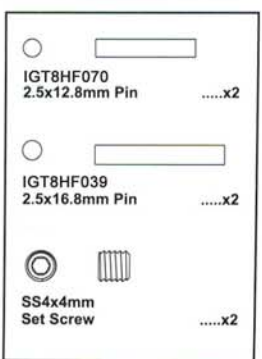

IGT8HF070  
2.5x12.8mm Pin .....x2

IGT8HF039  
2.5x16.8mm Pin .....x2

SS4x4mm  
Set Screw .....x2

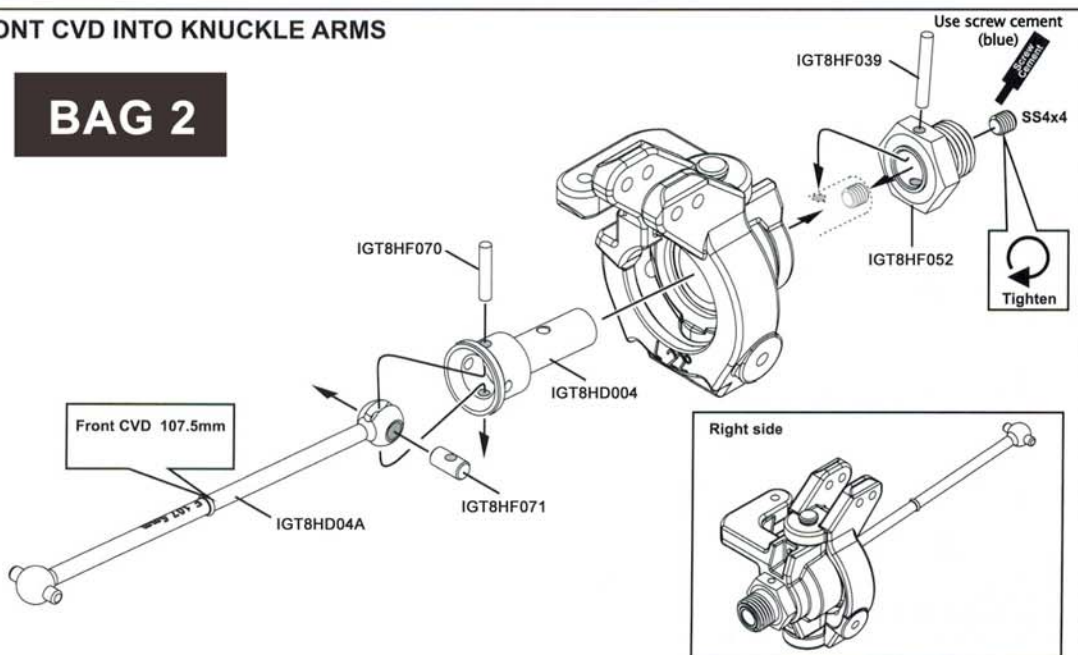

Use screw cement  
(blue)

IGT8HF039

IGT8HF052

SS4x4

Tighten

IGT8HF070

IGT8HD004

IGT8HF071

Front CVD 107.5mm

IGT8HD04A

**Right side**

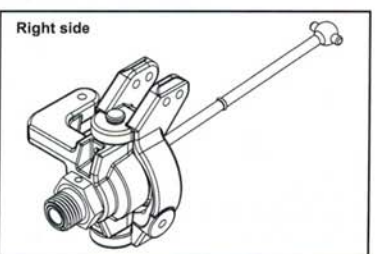

## 14 ASSEMBLY OF THE KNUCKLE ARMS ONTO FRONT LOWER ARMS

Assemble both right and left sides.

**Step detail**

Ensure Free Movement

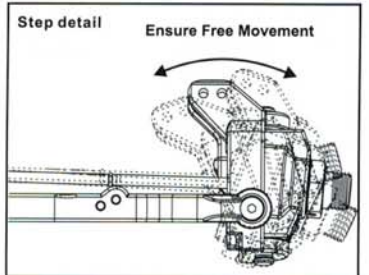

**Step 1**

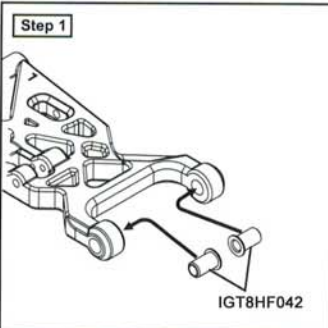

IGT8HF042

**Step 2**

\*Insert the front drive shaft into cap joint before assembly.

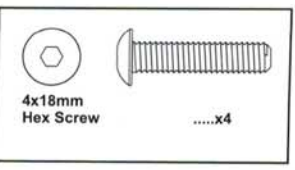

4x18mm  
Hex Screw .....x4

Do Not Over Tighten

Do Not Over Tighten

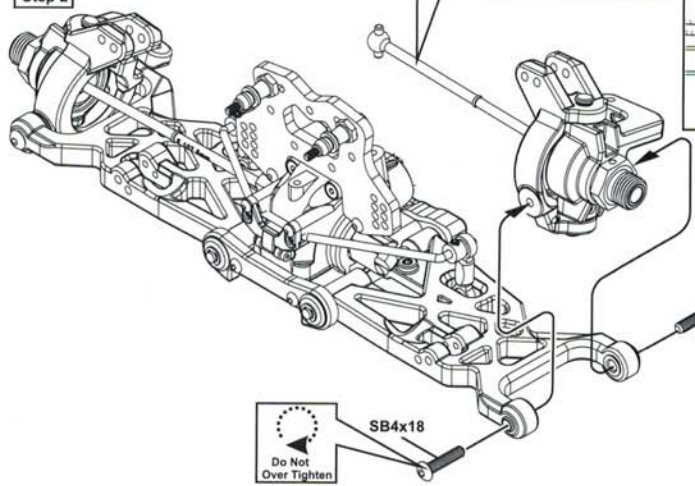

SB4x18



SB4x18

# 15 ASSEMBLY OF THE FRONT UPPER ARMS

**BAG 2**

Assemble both left and right sides.

LEFT SIDE

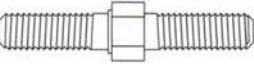

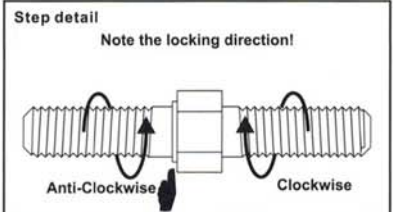
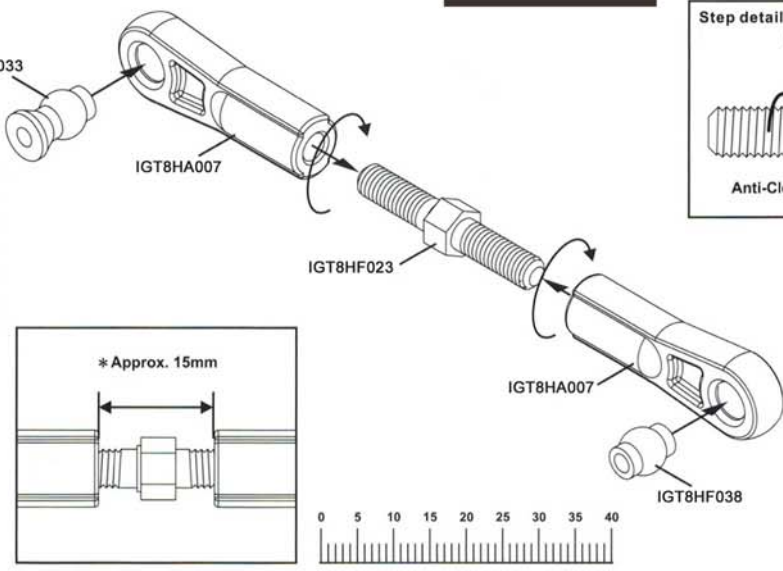
-  IGT8HF033 7x12mm Ball .....x2
-  IGT8HF038 7mm Ball .....x2
-  IGT8HF023 5x35mm Turnbuckle .....x2



# 16 ASSEMBLY OF THE FRONT UPPER ARMS

Assemble both right and left sides.

LEFT SIDE

-  SNN3mm Nylon Nut .....x4
-  SB3x25mm Hex Screw .....x2
-  SB3x20mm Hex Screw .....x2

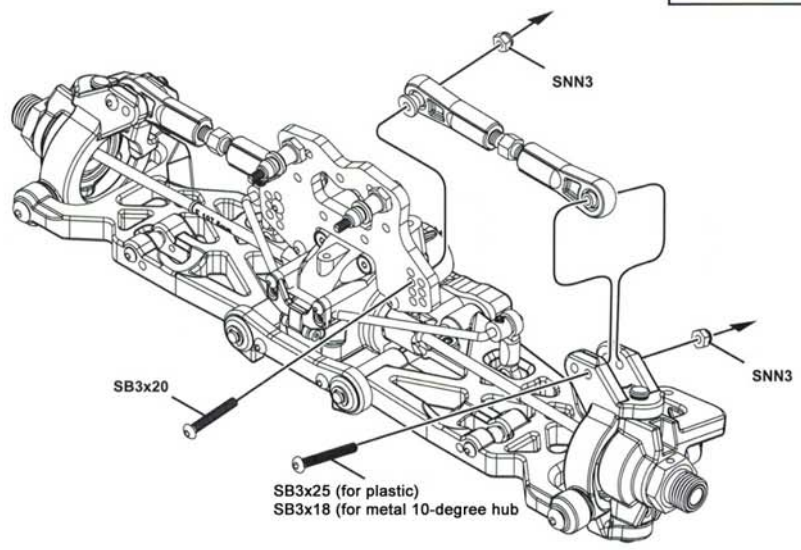

# 17 ASSEMBLY OF THE SERVO SAVER



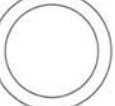

**BAG 3**

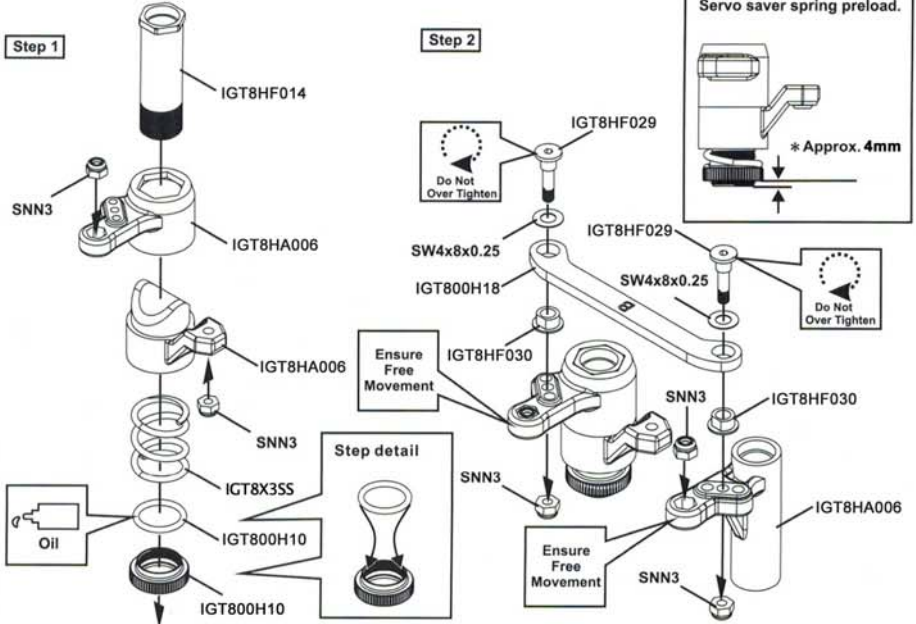
Servo saver spring preload.

-  IGT8HF029 Steering Plat Hex Screw .....x2
-  IGT800H10 12x1.7mm O-Ring .....x1
-  SNN3mm Nylon Nut .....x3
-  SW4x8x0.25 Washer .....x2

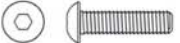

# 18 ASSEMBLY OF THE FRONT PLATE ONTO SERVO SAVER

-  SNN3mm Nylon Nut .....x1
-  SB3x10mm Hex Screw .....x1
-  SB3x12mm Hex Screw .....x2
-  SW3x6x0.5 Washer .....x2

**BAG 3**

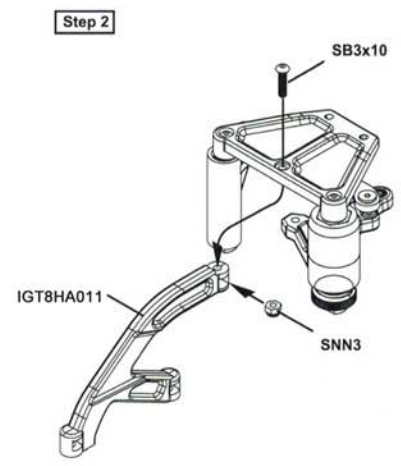
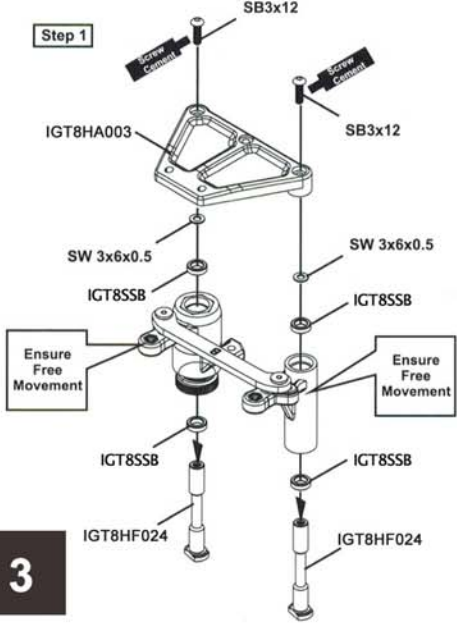

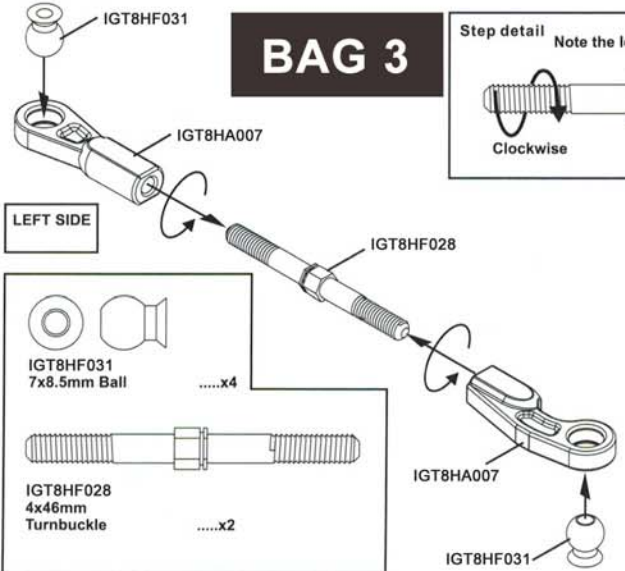

# 19 ASSEMBLY OF THE STEERING TIE-ROD

Make two steering rods for left and right hand sides.

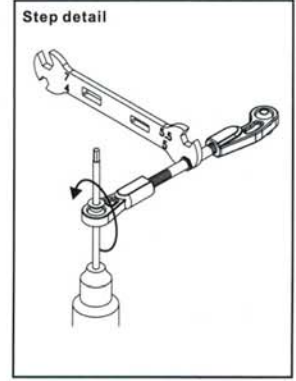
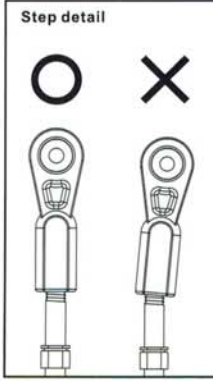
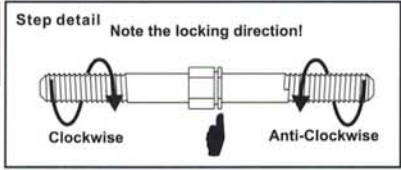

**BAG 3**

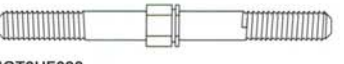

-  IGT8HF031 7x8.5mm Ball .....x4
-  IGT8HF028 4x46mm Turnbuckle .....x2

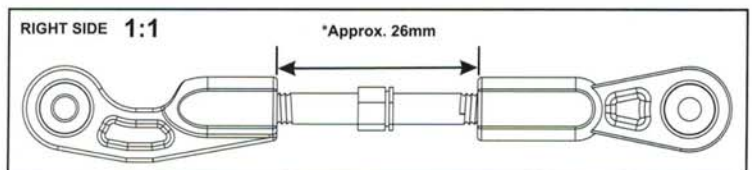

# 20 ASSEMBLY OF THE STEERING TIE-ROD

**BAG 3**

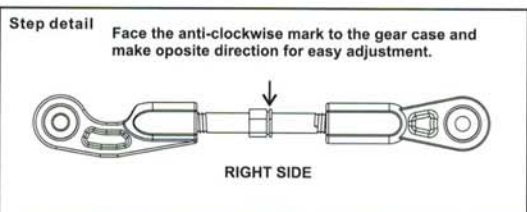

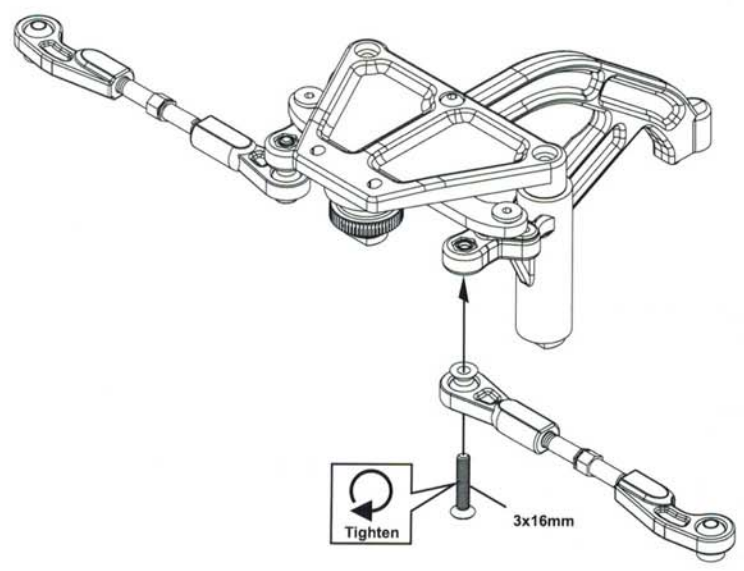

-  SF3x16mm Flat Head Hex Screw .....x2

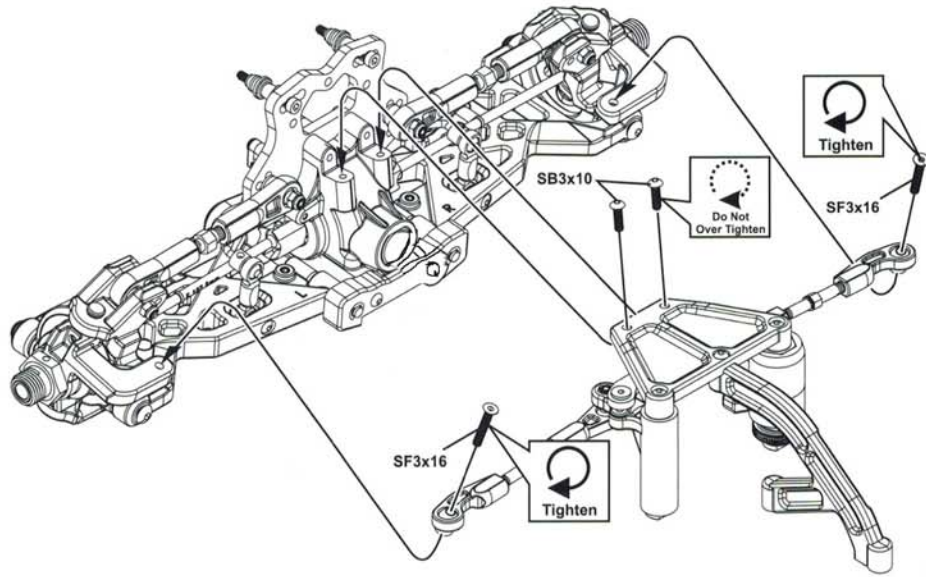

**21 ASSEMBLY OF THE SERVO SAVE R ONTO THE FRONT GEAR BOX**

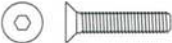



-  SF3x16mm Flat Head Hex Screw .....x2
-  SB3x10mm Hex Screw .....x2

**22 ASSEMBLY OF THE REAR GEAR CASE**

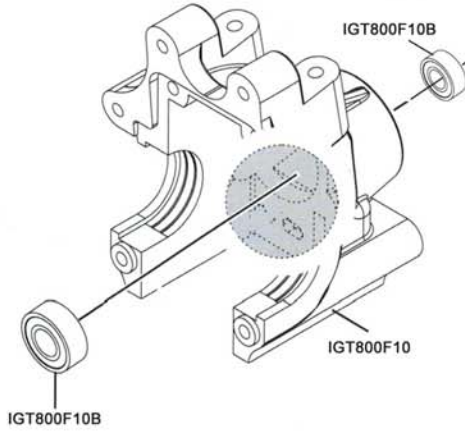
**BAG 4**



-  Ball Bearing .....x1
-  Ball Bearing .....x1

**23 ASSEMBLY OF THE REAR GEAR CASE**

**BAG 4**

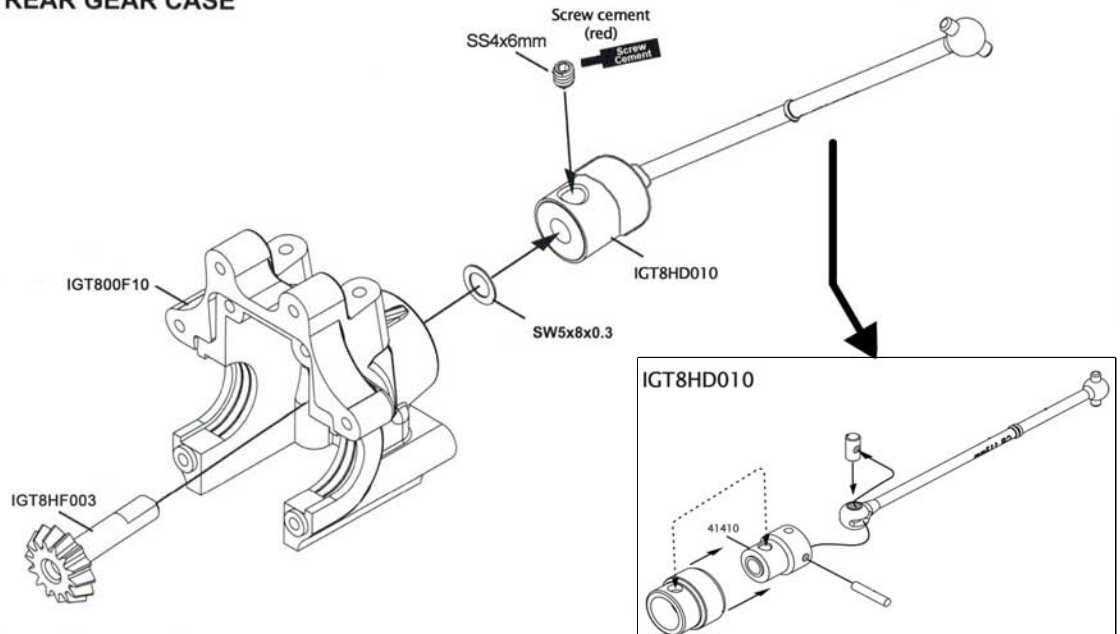

-  SW5x8x0.3mm Washer .....x1



**24 ASSEMBLY OF THE REAR DIFFERENTIAL INTO GEAR CASE**

Adjust the backlash with the Shims.

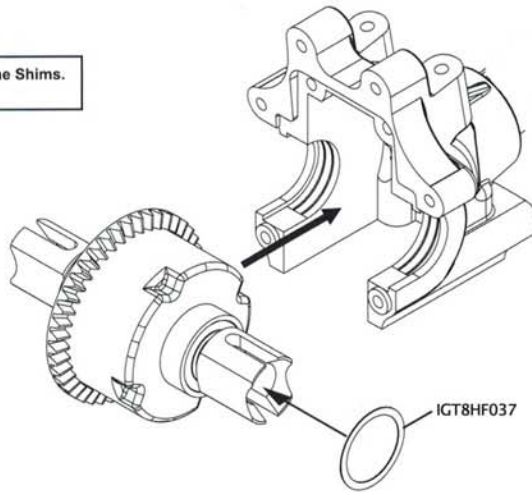

**BAG 1**

**BAG 4**

**25 ASSEMBLY OF THE REAR GEAR CASE COVER AND LOWER ARM HOLDERS**

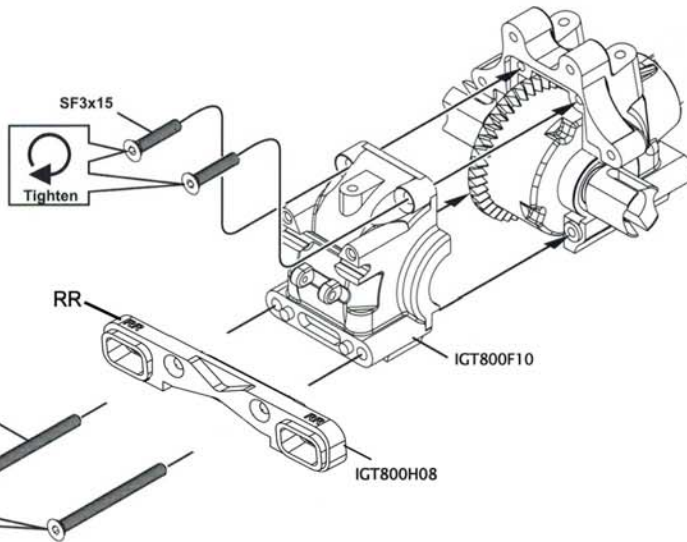
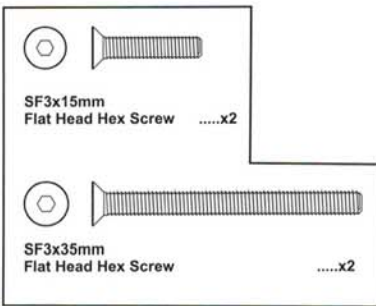

**BAG 4**

**BAG 11**

**26 ASSEMBLY OF THE REAR BRACE MOUNT**

**BAG 2**

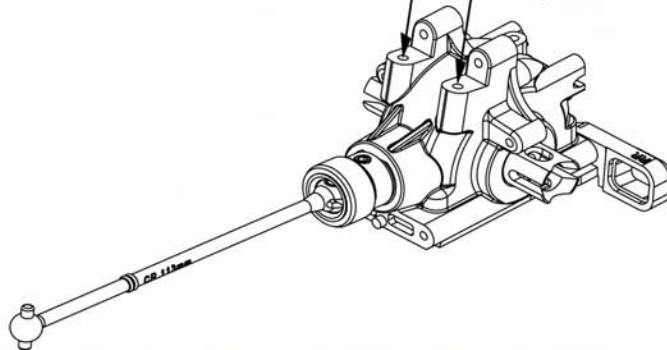
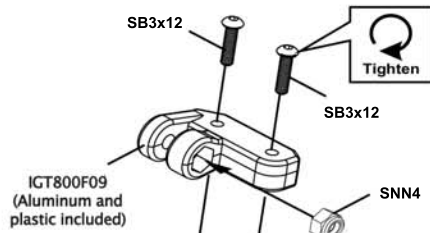

**27 ASSEMBLY OF THE REAR SHOCK STAY**

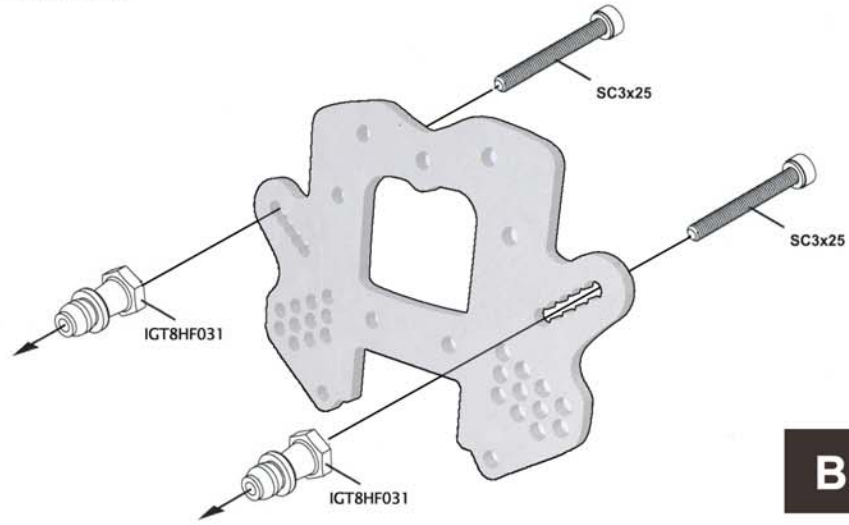

**BAG 4**

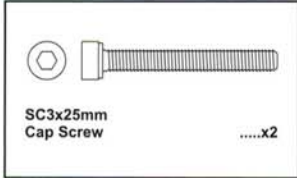

**28 ASSEMBLY OF THE REAR SHOCK STAY ONTO REAR GEAR CASE**

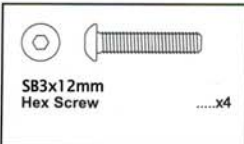
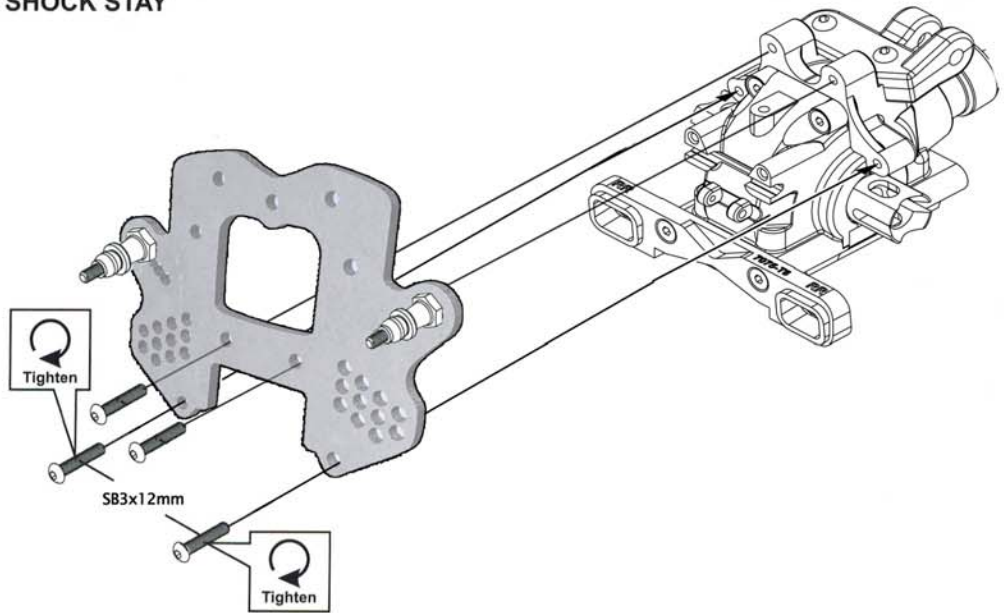

**29 ASSEMBLY OF THE REAR LOWER ARMS**

Assemble both right and left sides.

**BAG 4**

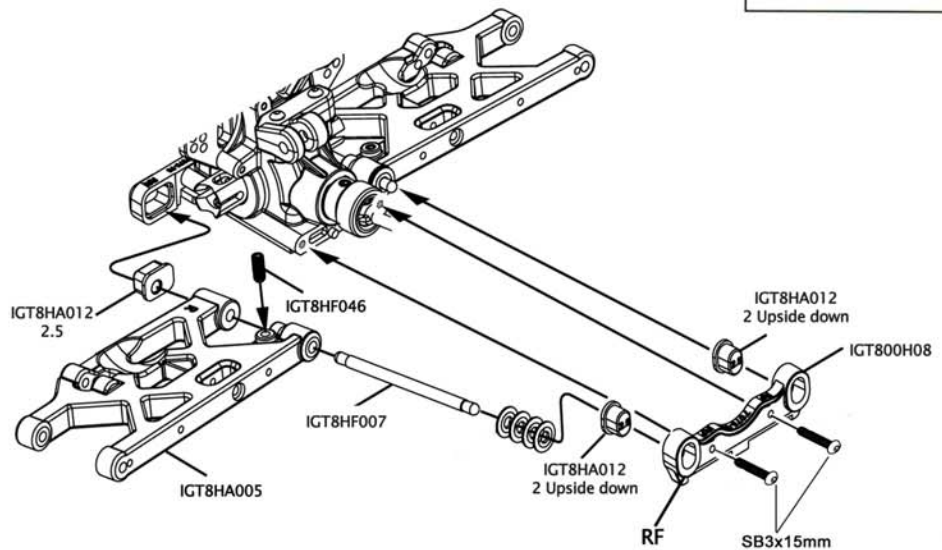

### 30 ASSEMBLY OF THE SHOCK EXTENSIONS

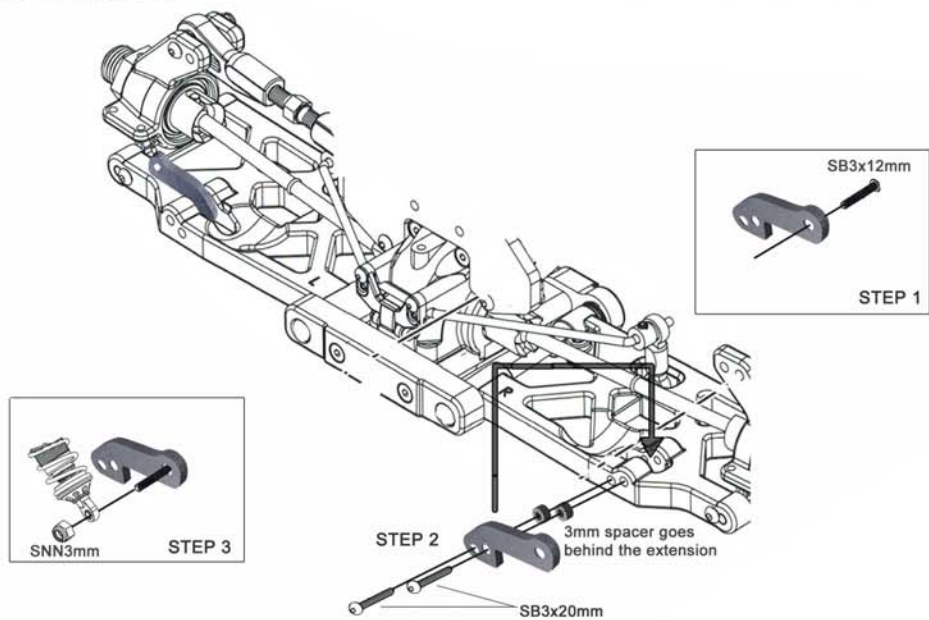

### 31 ASSEMBLY OF THE REAR STABILIZER

**BAG 4**

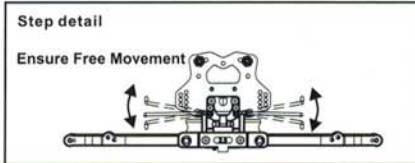
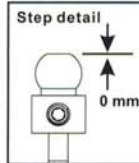

- SB2.5x8mm Hex Screw .....x2
- SC2x12mm Cap Screw .....x1
- SB3x18mm Hex Screw .....x2
- SS3x3mm Set Screw .....x4

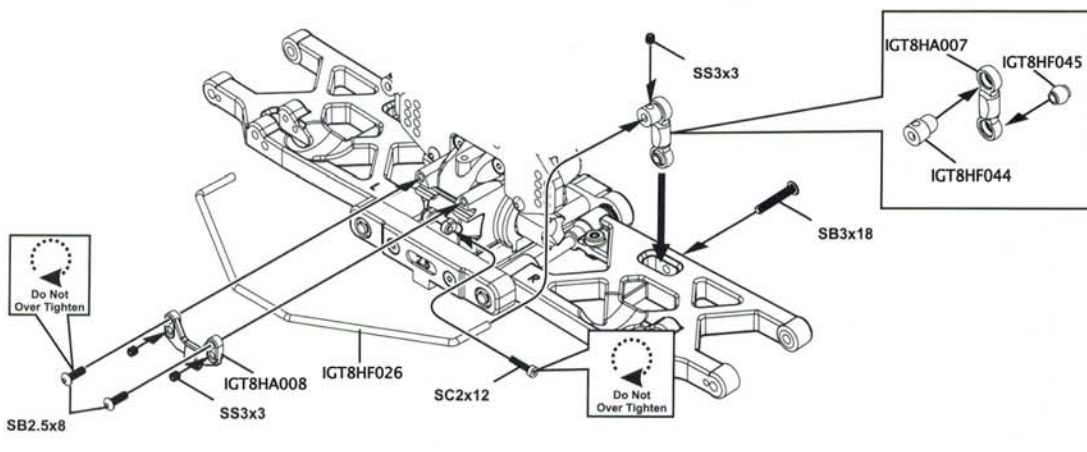

### 32 ASSEMBLY OF THE REAR WHEEL HUBS

Assemble both right and left side.

**BAG 4**

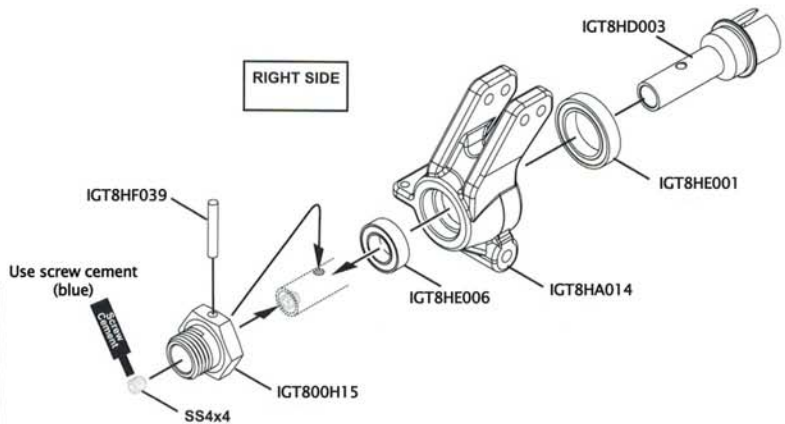

- IGT8HF039 2.5x16.8mm Pin .....x2
- 4x4mm Set Screw .....x2

### 33 ASSEMBLY OF THE REAR SUSPENSION ARMS

Assemble both right and left sides.

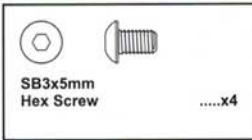
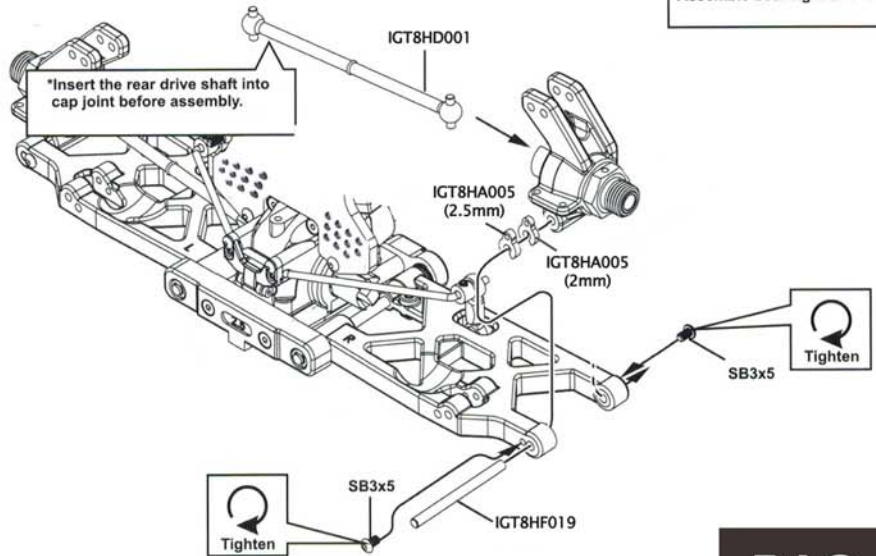
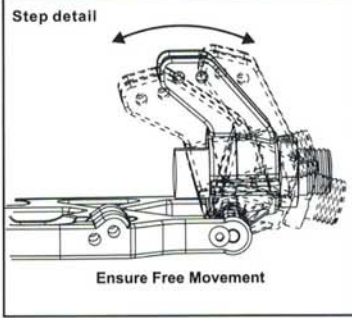

**BAG 4**

### 34 ASSEMBLY OF THE REAR UPPER ARMS

Assemble both left and right sides.

RIGHT SIDE

**BAG 4**

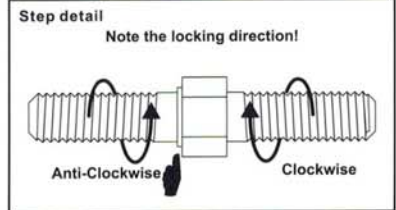
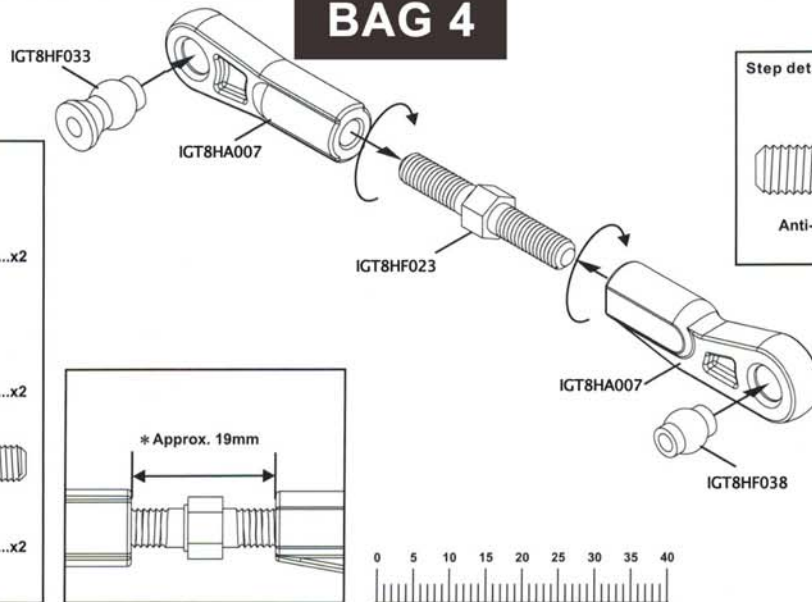
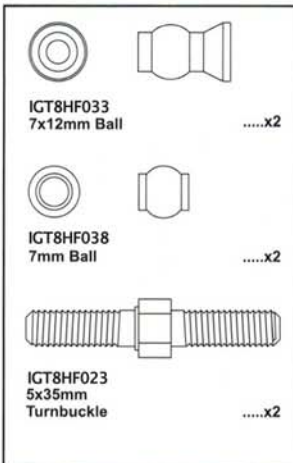

### 35 ASSEMBLY OF THE REAR UPPER ARMS

Assemble both right and left sides.

**BAG 4**

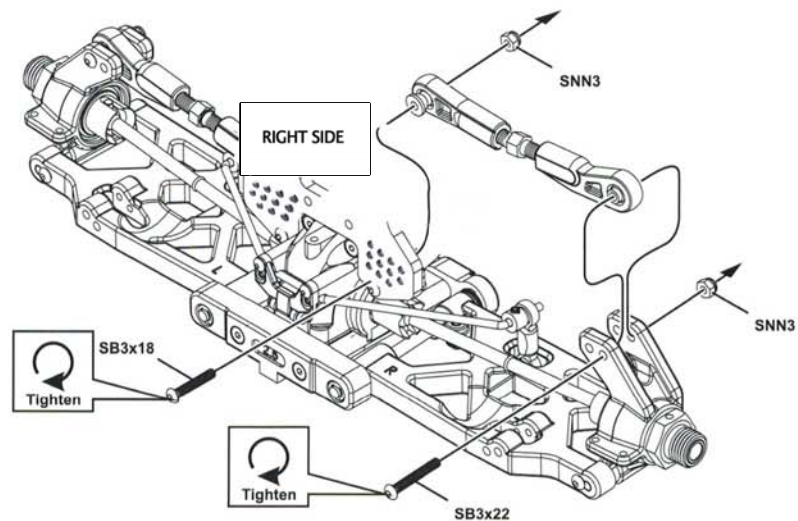
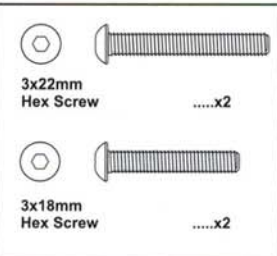

36 ASSEMBLY OF THE REAR CENTER BRACE

BAG 4

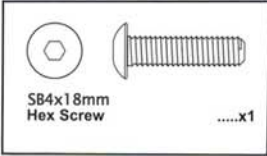
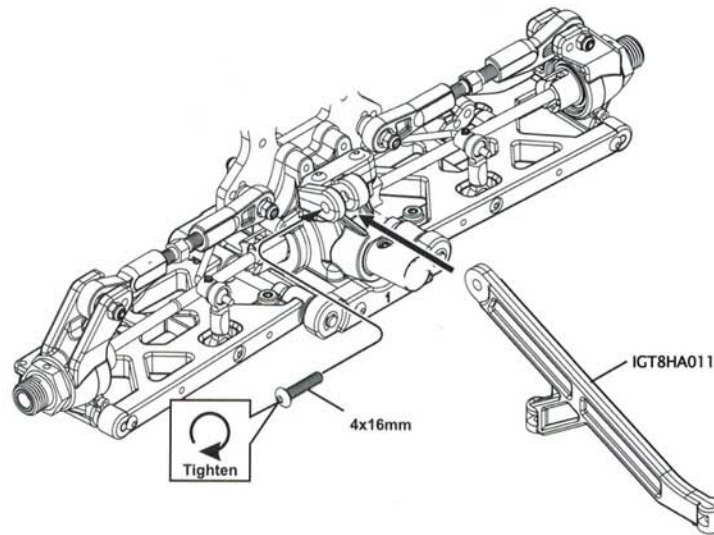

37 ASSEMBLY OF THE REAR BODY POST

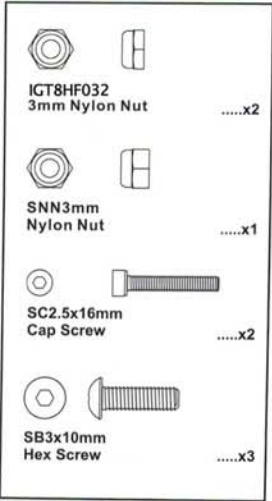
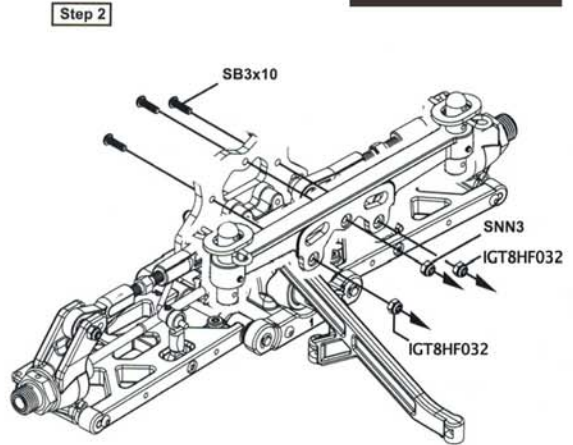
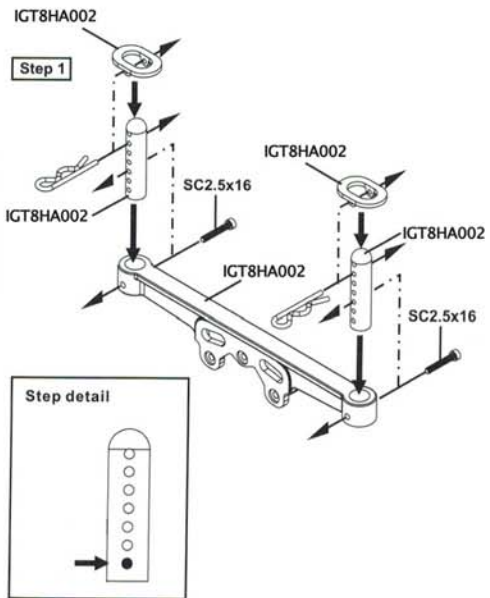

BAG 8



38



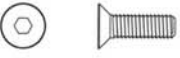

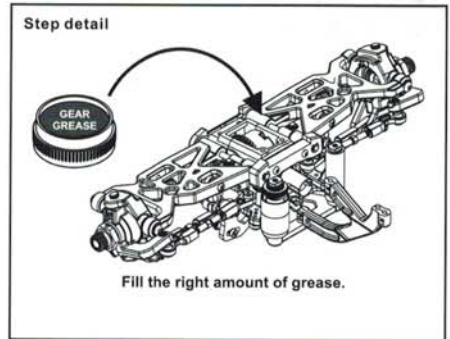
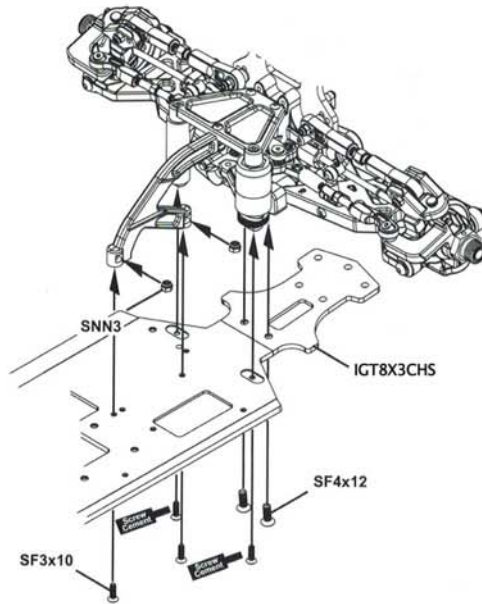

### 39 ASSEMBLY OF THE FRONT GEAR CASE ONTO CHASSIS

-  SF3x10mm Flat Head Hex Screw .....x4
-  SF4x12mm Flat Head Hex Screw .....x2
-  SNN3mm Nylon Nut .....x2



### 40 ASSEMBLY OF THE REAR GEAR CASE ONTO CHASSIS

-  SF3x10mm Flat Head Hex Screw .....x2
-  SF4x12mm Flat Head Hex Screw .....x2
-  SF4x16mm Flat Head Hex Screw .....x2
-  SNN3mm Nylon Nut .....x2

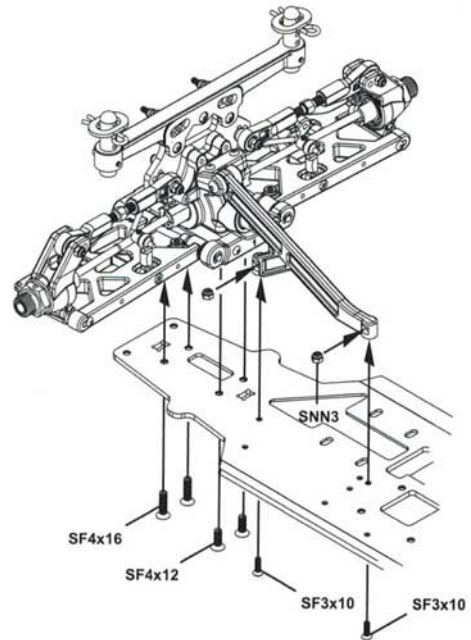
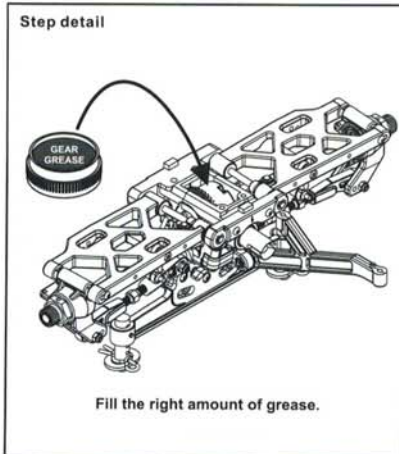

### 41 ASSEMBLY OF THE CENTER DIFF. ONTO CHASSIS

-  SF4x12mm Flat Head Hex Screw .....x4

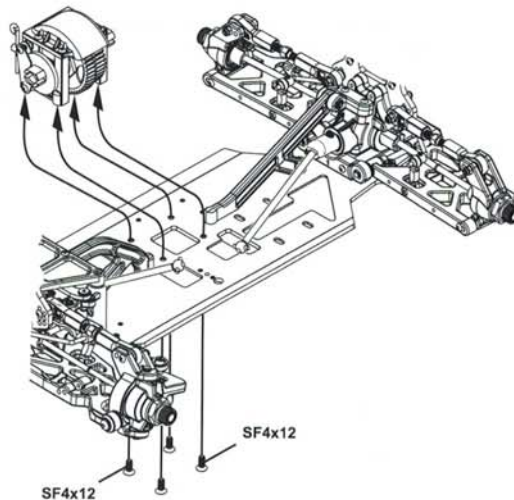



**43 ASSEMBLY OF THE FUEL TANK ONTO CHASSIS**

**BAG 7**

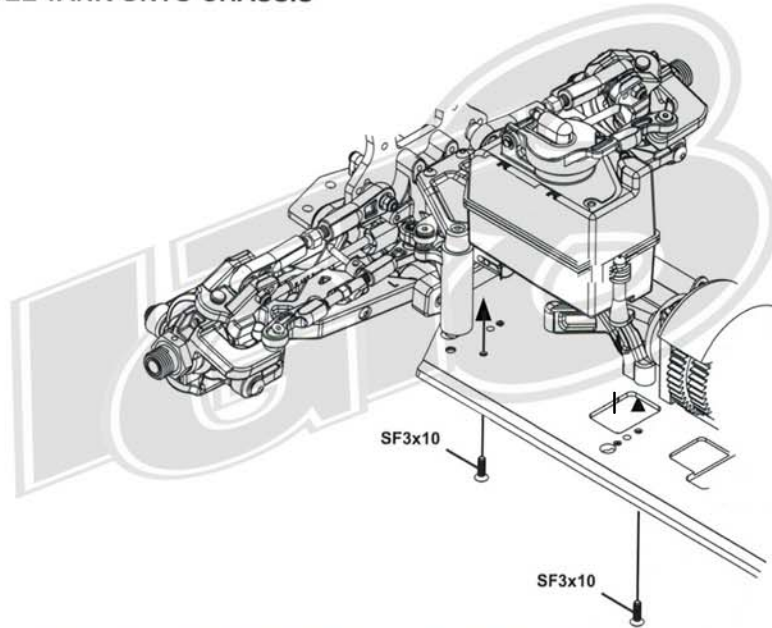

SF3x10mm  
Flat Head Hex Screw .....x2

**44 ASSEMBLY OF THE STEERING ROD**

**BAG 10**

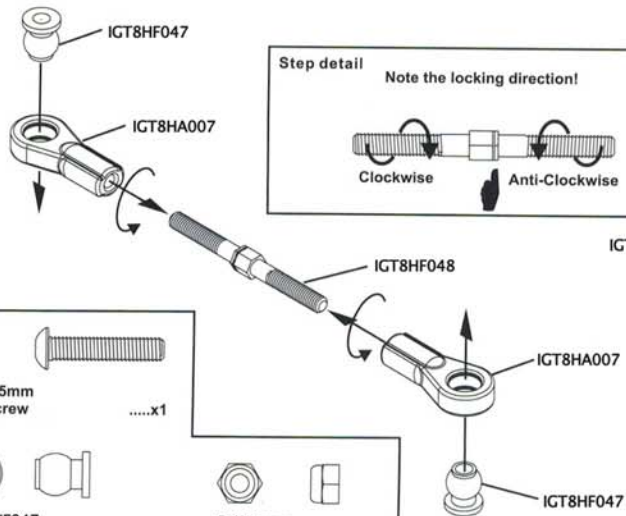

**Step detail**

Use tools to tighten as shown.

SB3x15mm  
Hex Screw .....x1

IGT8HF047  
6mm Ball and socket .....x2

SNN3mm  
Nylon Nut .....x1

Approx. 23.5mm

### 45 ASSEMBLY OF THE STEERING SERVO AND RADIO TRAY

**BAG 10**

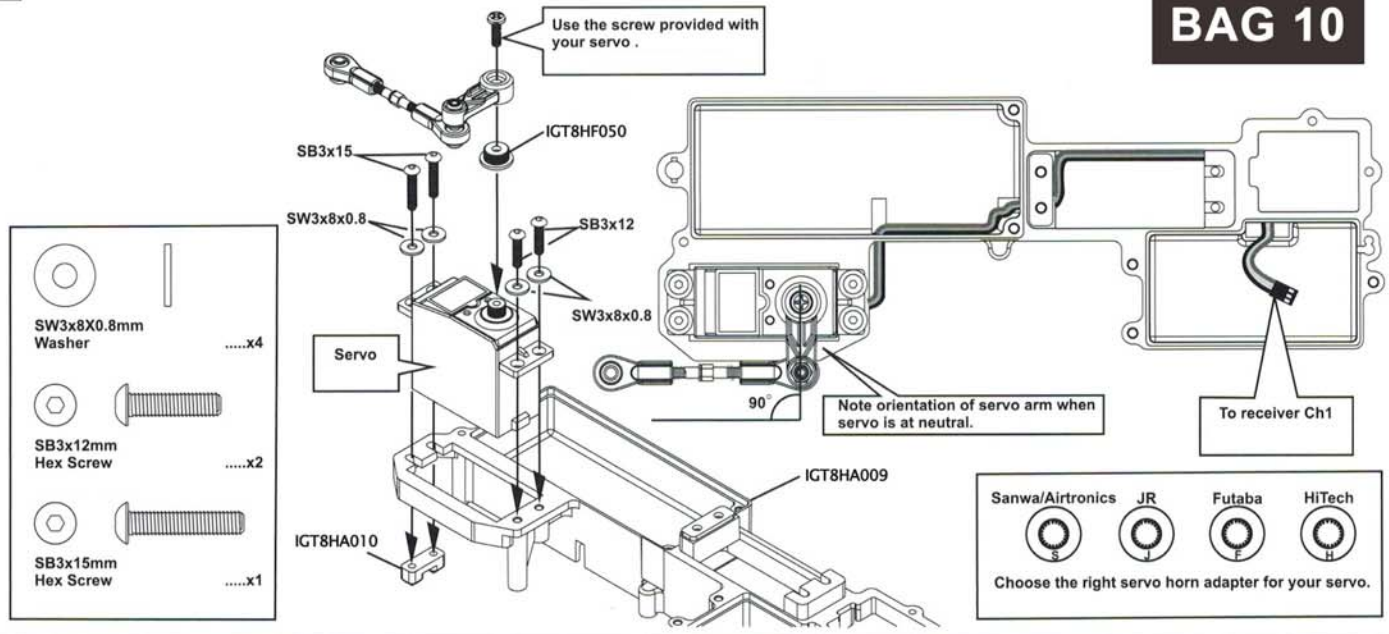

- SW3x8X0.8mm Washer .....x4
- SB3x12mm Hex Screw .....x2
- SB3x15mm Hex Screw .....x1

### 46 ASSEMBLY OF THE THROTTLE SERVO AND RADIO TRAY

**BAG 10**

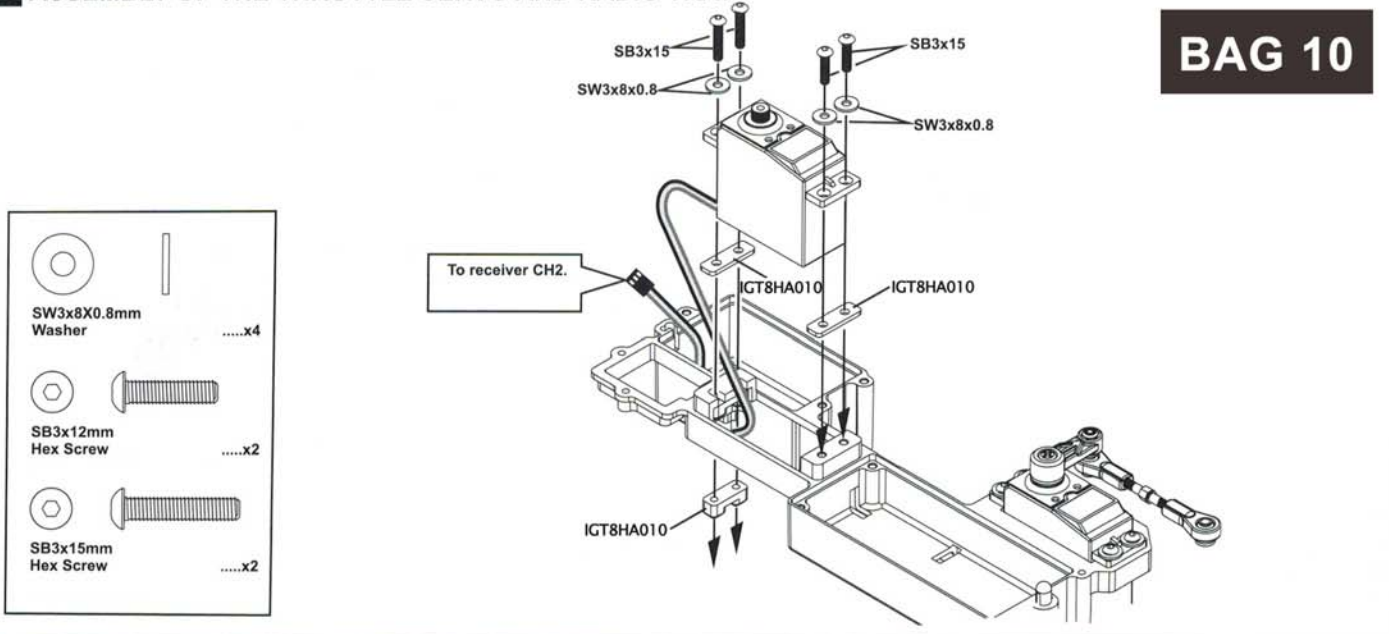

- SW3x8X0.8mm Washer .....x4
- SB3x12mm Hex Screw .....x2
- SB3x15mm Hex Screw .....x2

### 47 ASSEMBLY OF THE PERSONAL TRANSPONDER

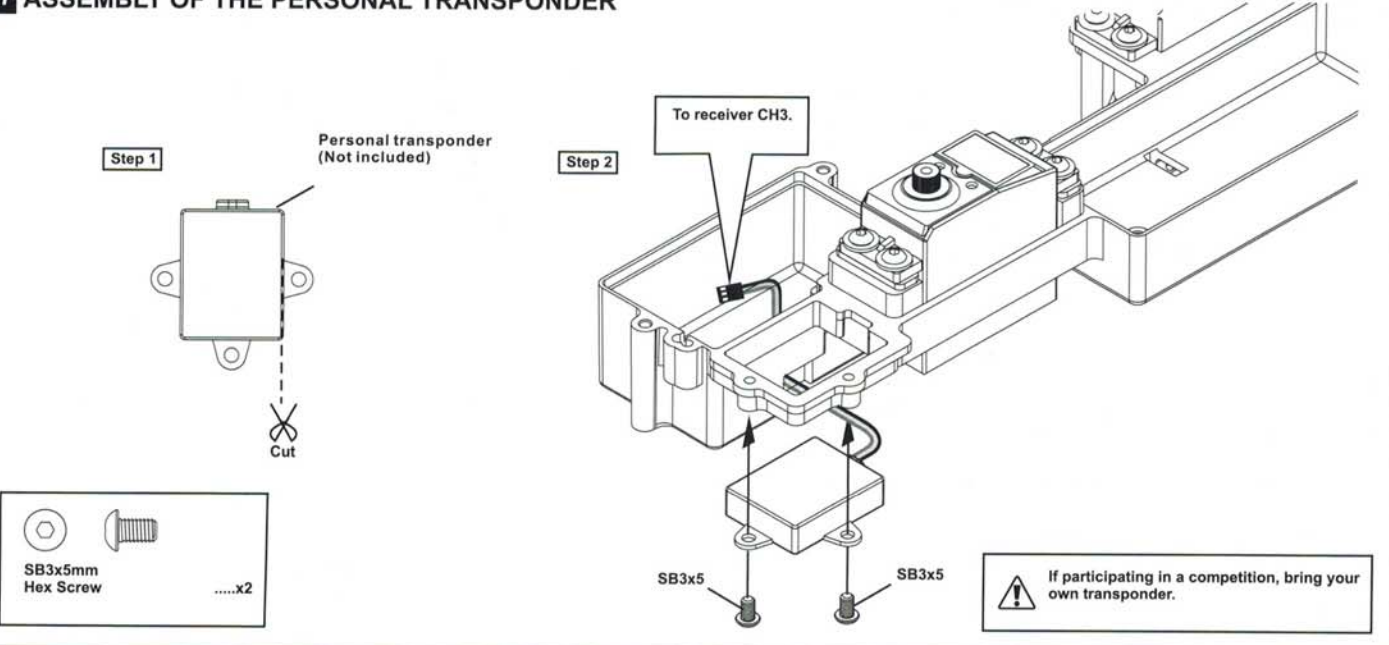

- SB3x5mm Hex Screw .....x2

If participating in a competition, bring your own transponder.



## 48 ASSEMBLY OF THE RECEIVER INTO RADIO CASE

**BAG 10**

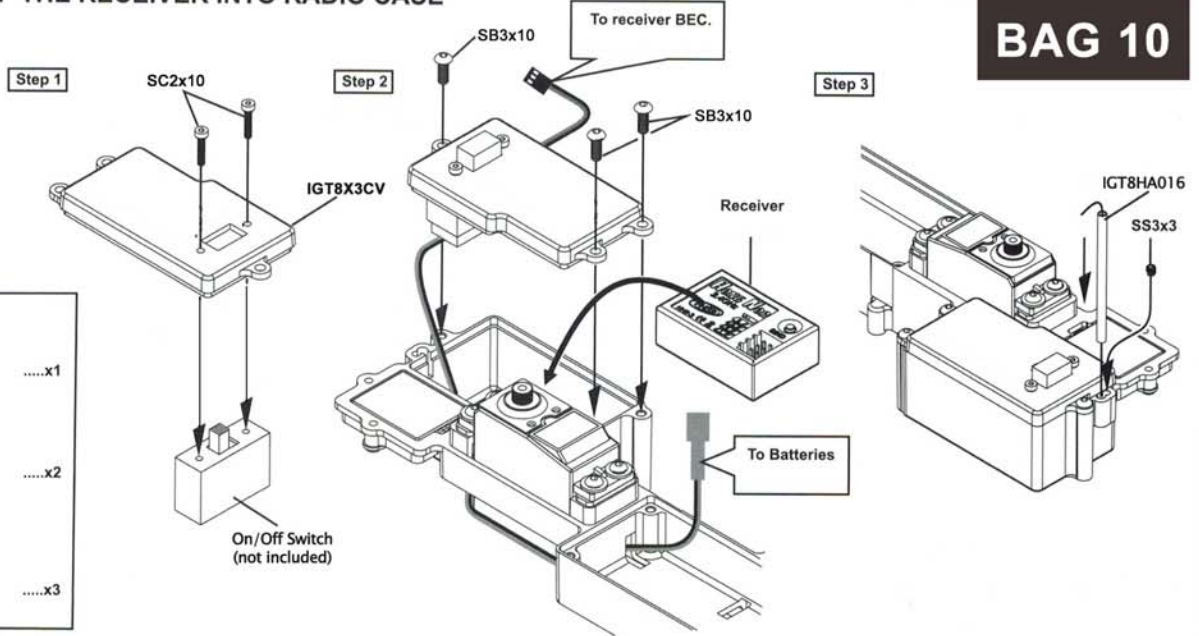

## 49 ASSEMBLY OF THE BATTERY BOX AND RADIO TRAY

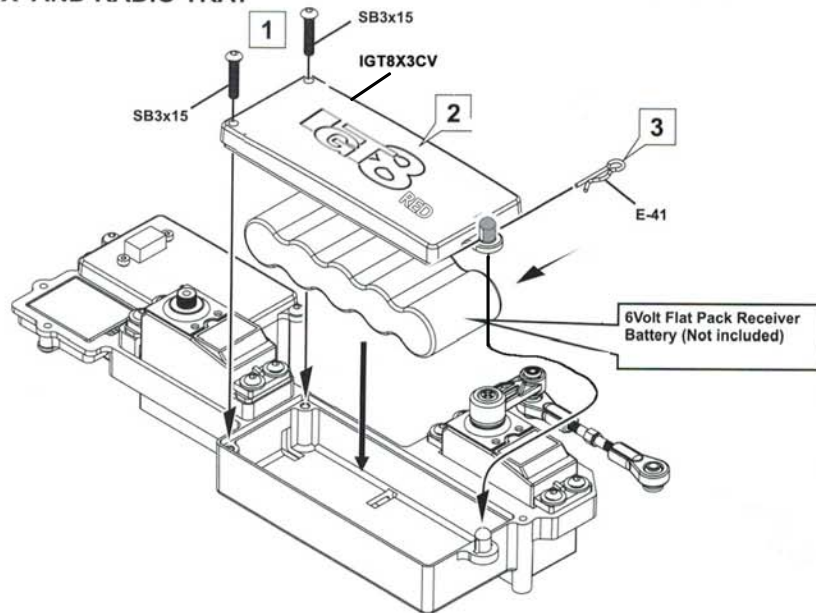

## 50 ASSEMBLY OF THE RADIO TRAY ONTO CHASSIS

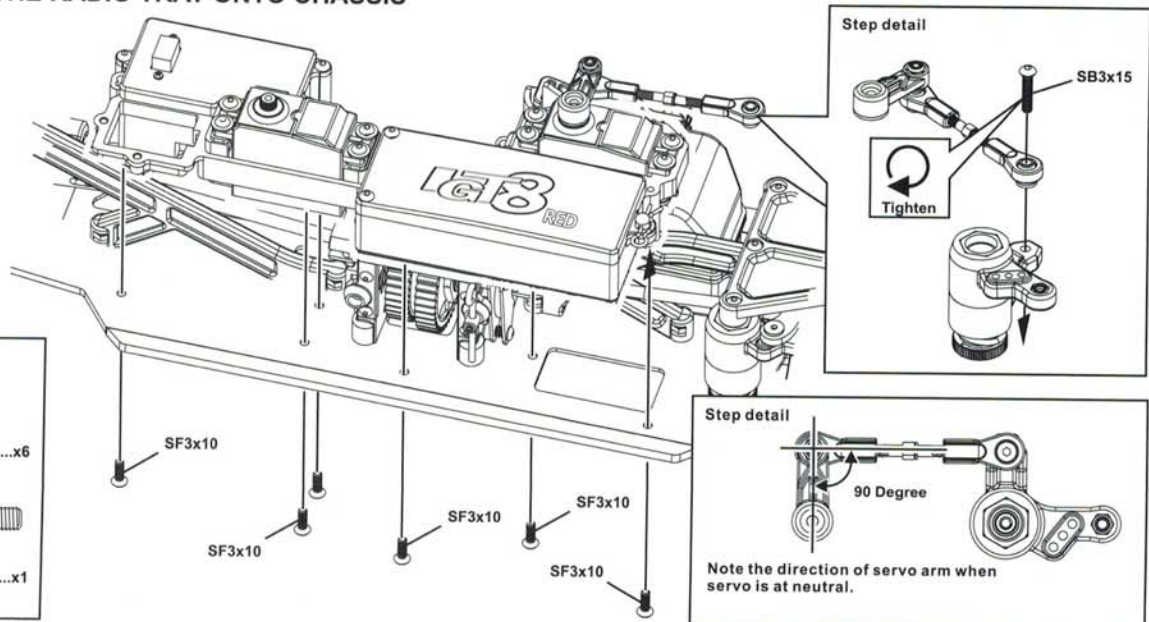

**51 ASSEMBLY OF THE ENGINE MOUNT AND FLYWHEEL**

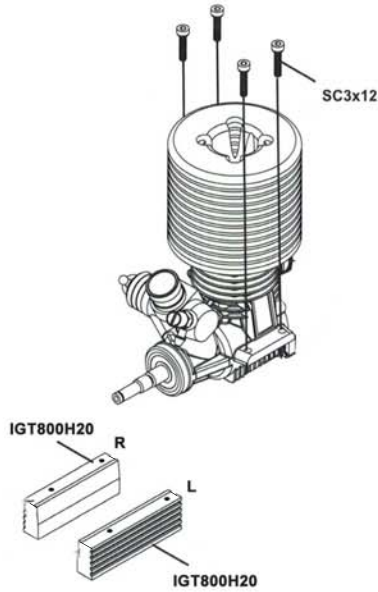
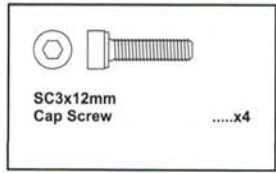

**BAG 6**

**52**





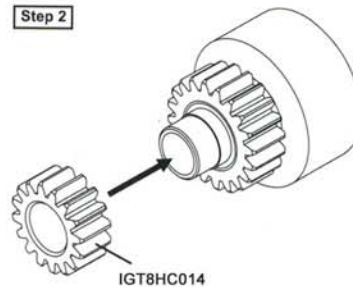
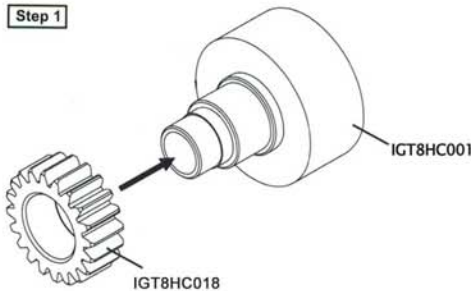

**53 ASSEMBLY OF THE CLUTCH BELL**



**BAG 6**

## 54 ASSEMBLY OF THE CLUTCH BELL

BAG 6

 SC3x8mm Cap Screw .....x1	 IGT8HE002 5x8x2.5mm Ballbearings .....x3
 SW5x8x0.3mm Washer .....x1	 IGT8HE003 5x10x4mm Ballbearings .....x1
 SW3x8x0.8mm Washer .....x1	

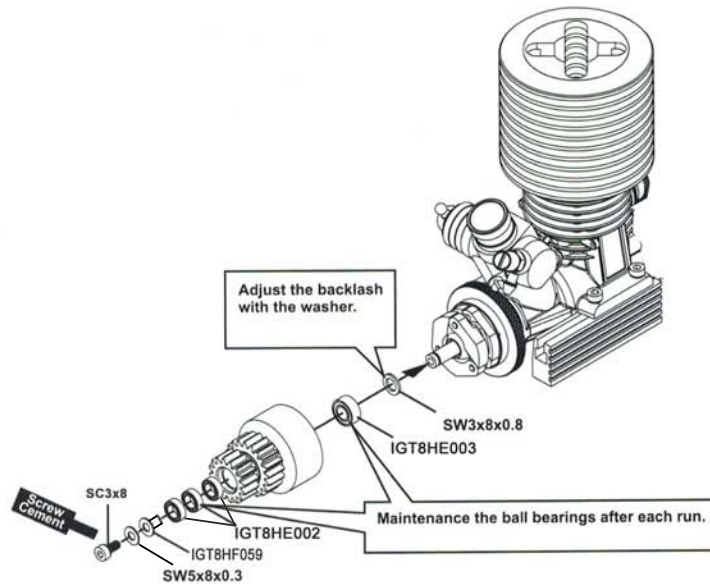

## 55 ASSEMBLY OF THE ENGINE ONTO CHASSIS

  
 IGT8HF074  
4x8mm  
Engine Mount Screw  
.....x4

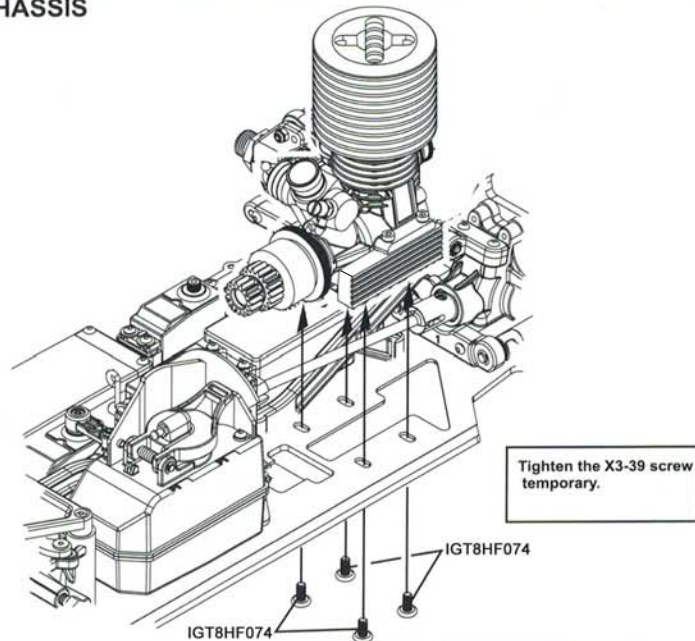

## 56 ADJUST ENGINE AND SPUR GEAR MAINTENANCE

EXTREMELY IMPORTANT

Step 1

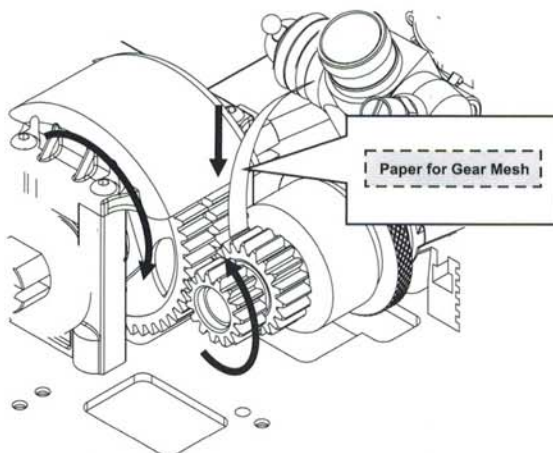

Insert a notebook paper between spur gear and motor gear to make correct gear mesh.

Step 2

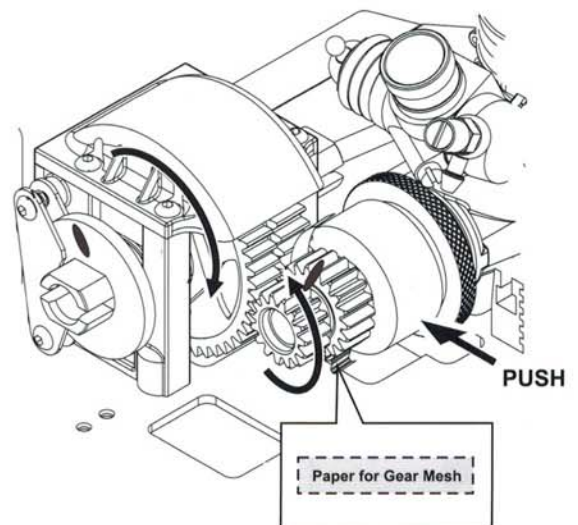

## 57 ADJUST ENGINE AND SPUR GEAR MAINTENANCE

**EXTREMELY IMPORTANT**

Step 3

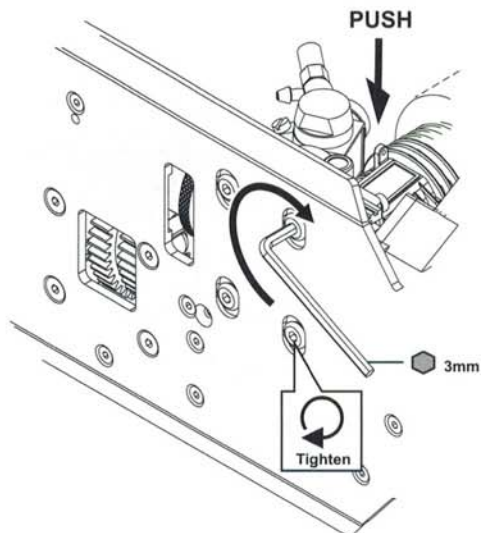

Step 4

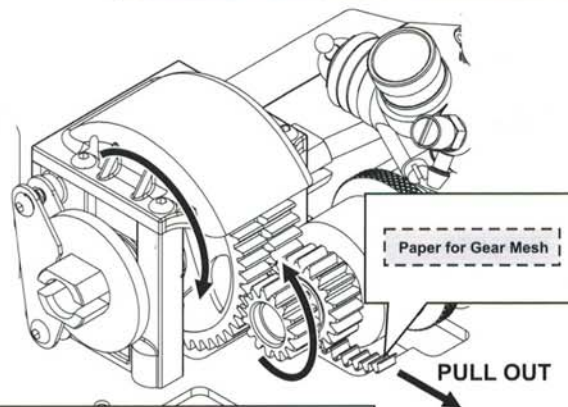

- Adjust the engine mount position to get proper gear mesh.
- To get a correct gear mesh, place a piece of notebook paper between the gears and tighten the engine mount screws.
- If the gear mesh is not correct the spur gear will be damaged.

## 58 ROLL BAR INSTALLATION

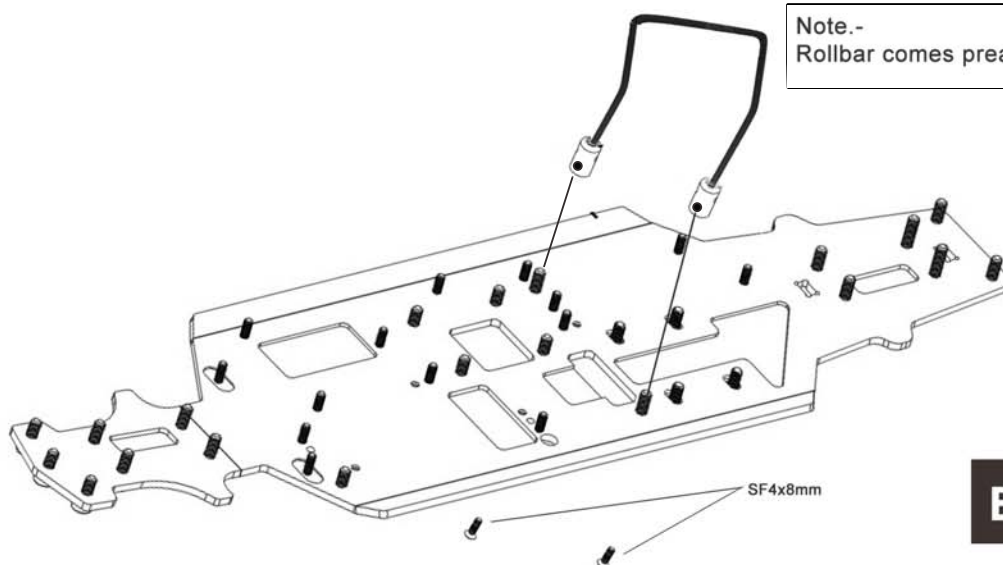

Note.-  
Rollbar comes preassembled

**BAG 11**

## 59 ASSEMBLY OF THE MUFFLER ONTO THE ENGINE

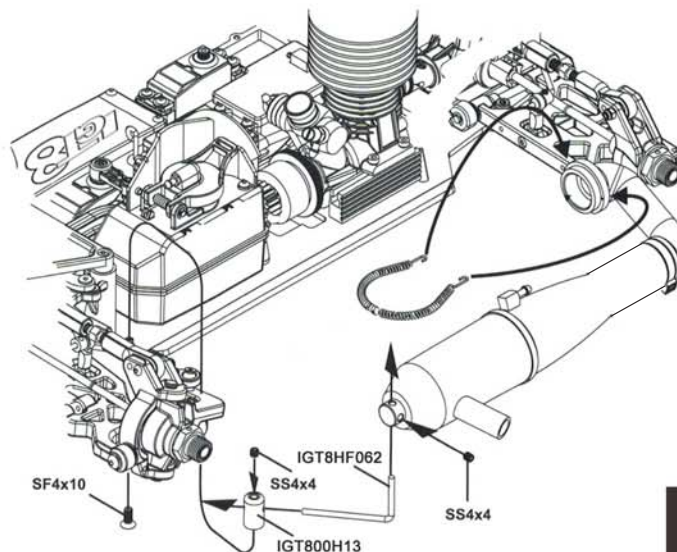

SF4x10mm  
Flat Head Screw .....x1



SS4x4mm  
Set Screw .....x2

**BAG 7**

# 60 ASSEMBLY OF THE MUFFLER ONTO THE ENGINE

Step detail

## BAG 6

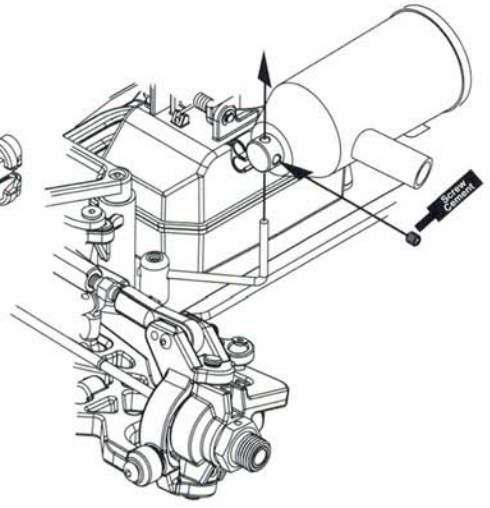
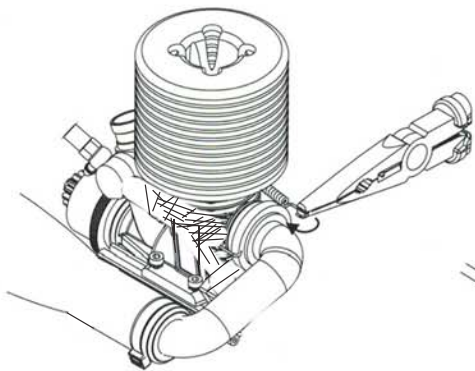
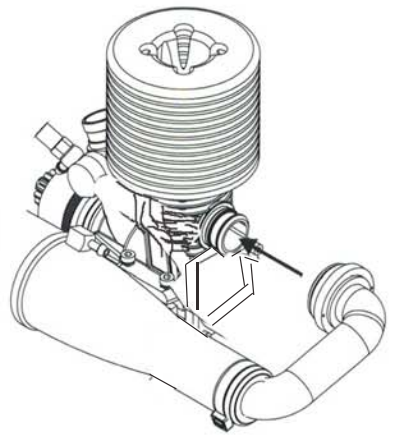
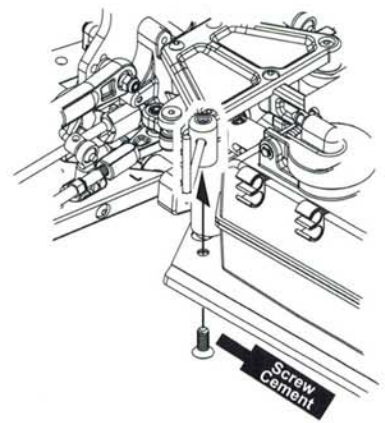
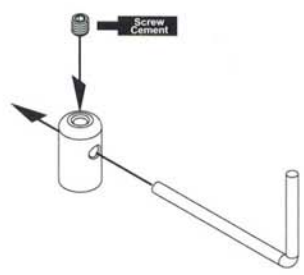

# 61 ASSEMBLY OF THE THROTTLE LINKAGE

## BAG 10

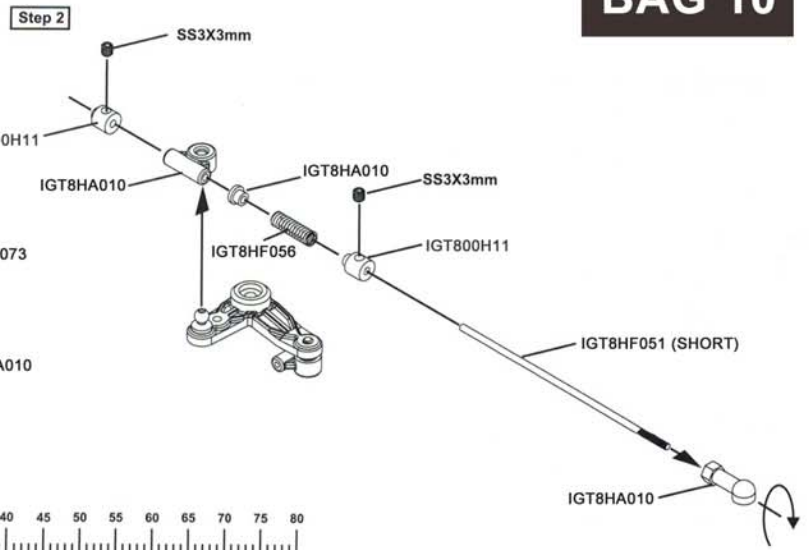
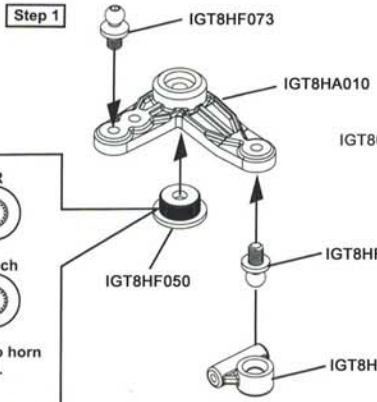

Sanwa/Airtronics JR  
Futaba HiTech

Choose the right servo horn adapter for your servo.

SS3x3mm Set Screw .....x2

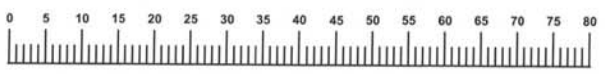

## 65 ASSEMBLY OF THE THROTTLE LINKAGE ONTO SERVO

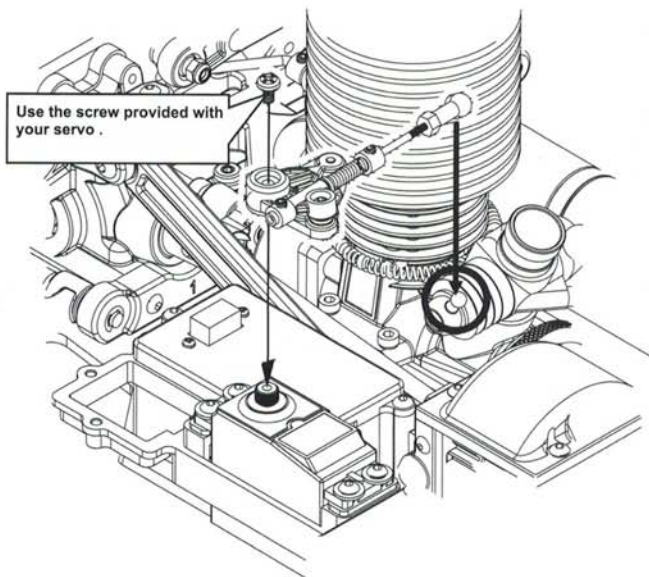

Step detail

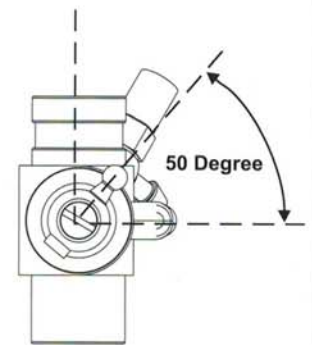

## 66 ASSEMBLY OF THE BRAKE LINKAGE

**BAG 10**

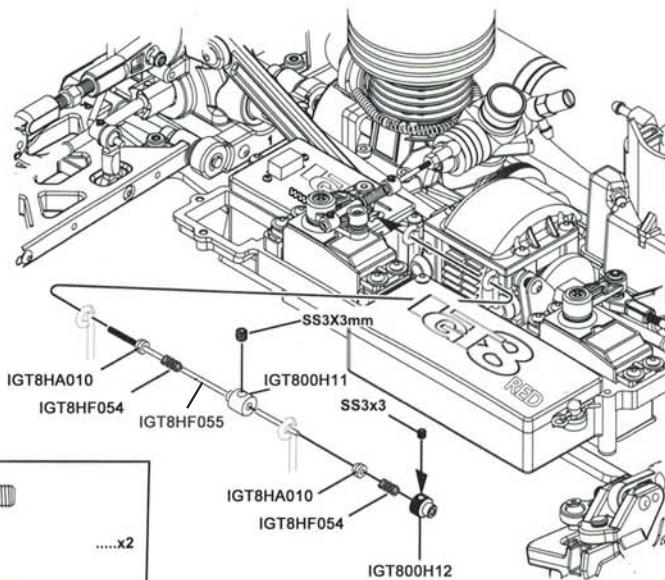

## 67 ADJUSTING THE ENGINE CONTROL LINKAGES

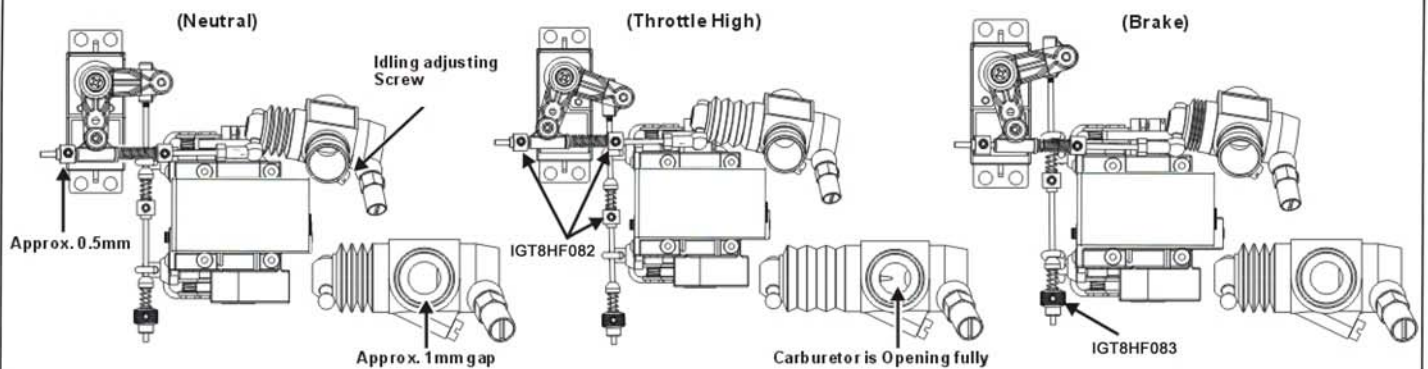

- \* Turn on the Transmitter then Receiver and set the Engine Control Servo Trim at the neutral position.
- \* Adjust the idling adjusting screw on the Carburetor to be open approx. 1mm gap.
- \* Adjust both of the #158 Engine Control and Brake linkage accordingly.
- \* Adjust the Engine while it is not running.

- \* Adjust the Servo-Horn mounting position for the Carburetor to be full open.
- \* Change the pivot mounting position on the servo horn in case the Carburetor is not opening fully or if it is opening excessively. Or if available on the Transmitter, adjust the Throttle high end point to the correct position.

- \* Adjust #158R so the brakes work smoothly.
- \* If the brakes apply too much or not enough, adjust A80A accordingly. Or if available on the Transmitter, adjust the High-End Brake adjustment.
- \* Adjust A-80A and #158 to Change the front or Rear Brake.

## 68 ASSEMBLY OF THE SHOCK SHAFTS

Assemble both left and right sides.

### BAG 9



Use 1.3x6 holes piston for front and rear.



SNN2.6mm Nylon Nut .....x2



SW2.6x6x0.5mm Washer .....x4

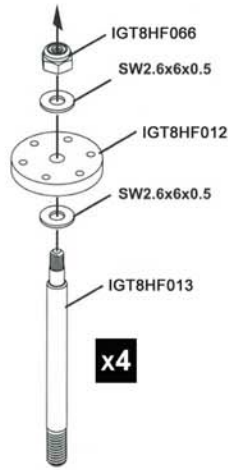

FRONT & REAR SHOCK

#### Step detail

- Hold the shock rod at its thread with side needle nosed pliers.
- Be careful not to damage the shock shaft.

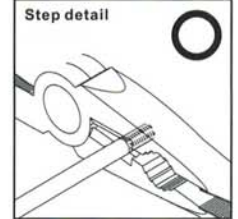
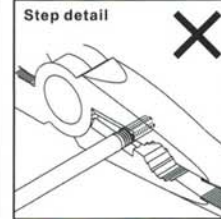
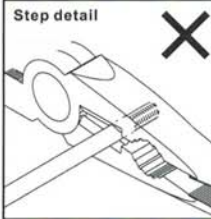
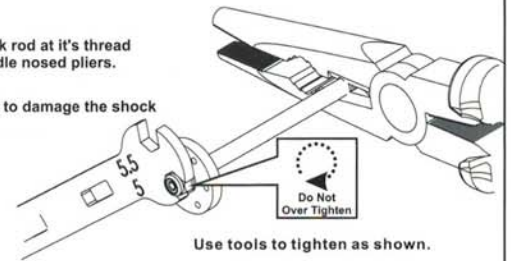

## 69 ASSEMBLY OF THE SHOCK O-RING

Assemble both left and right sides.



IGT8HF011 1mm Washer .....x4



IGT8HF011 2mm Washer .....x4



IGT8HF011 3.5mm O-Ring .....x8



IGT8HF065 P10 O-RING .....x4

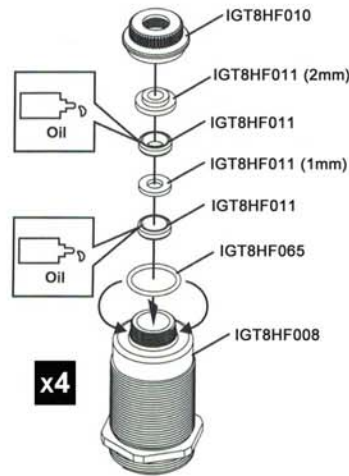

FRONT & REAR SHOCK

### BAG 9

## 70 ASSEMBLY OF THE SHOCK SHAFTS INTO SHOCK BODIES

Assemble both left and right sides.

### BAG 9

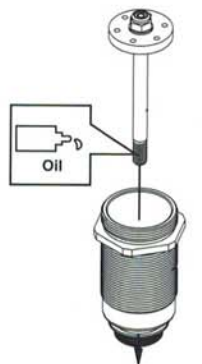

FRONT & REAR SHOCK

#### ⚠ EXTREMELY IMPORTANT

Do not push the shock shaft straight down, O-ring can be damaged.

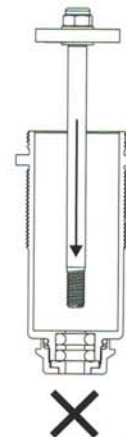

Slowly twist the shock shaft down to the bottom.

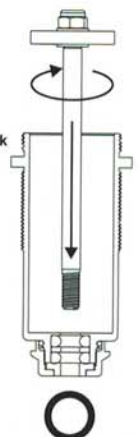

## 71 ASSEMBLY OF THE SHOCK ADJUST RING

Assemble both left and right sides.

### BAG 9

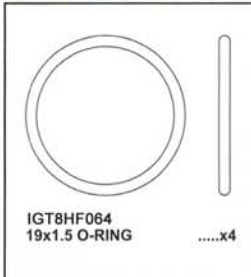

Step 1

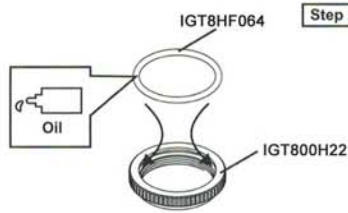

Fit the o-ring into groove before assembly.

Step 2

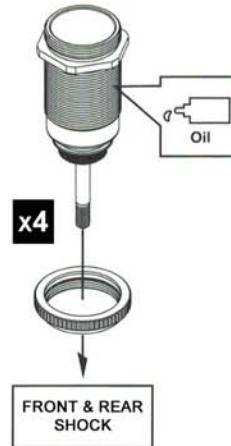

Step detail

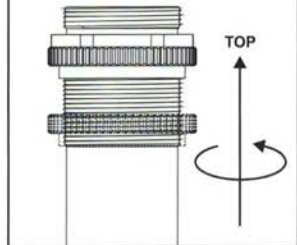

## 72 ASSEMBLY OF THE SHOCK BALL END

### BAG 9

Assemble both left and right sides.

Step detail



Attention distance.

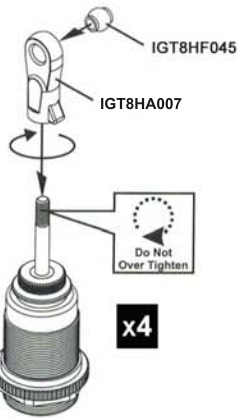

Step detail

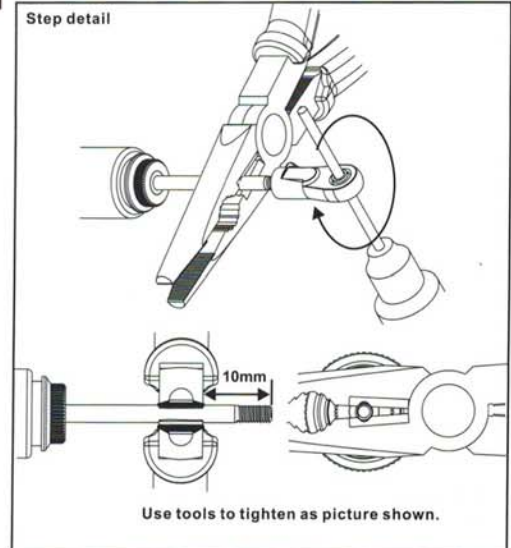

## 73 SETTING THE SHOCK REBOUND TO 100% (HIGH REBOUND)

Assemble both left and right sides.

FRONT & REAR SHOCK OIL  
#800

### BAG 9

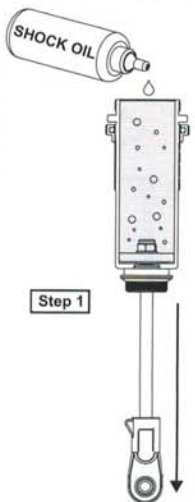

Step 1

Step 2



Step 3



Step 4

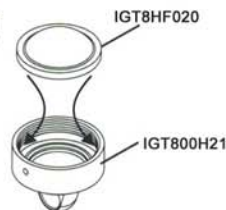

Step detail



TIGHTENED HALF WAY 50%

TIGHTENED 100%

Step 5



Step 6



- Leave the filled shock vertically for several minutes with the shock shaft fully extended.
- The remaining air bubbles will release.



## 74 SETTING THE SHOCK REBOUND TO 50% & 0% (MEDIUM REBOUND & LOW REBOUND)

TIGHTENED HALF WAY 50%

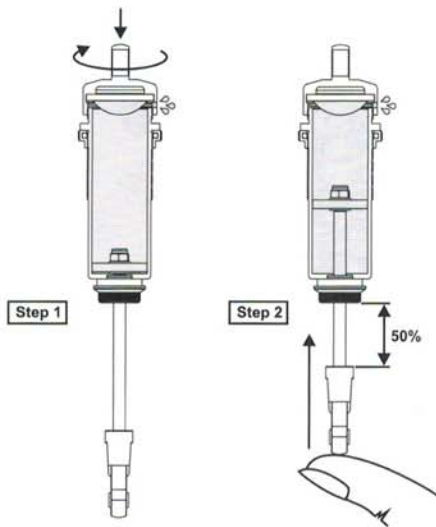

TIGHTENED 100%

TIGHTENED HALF WAY 50%

TIGHTENED 100%

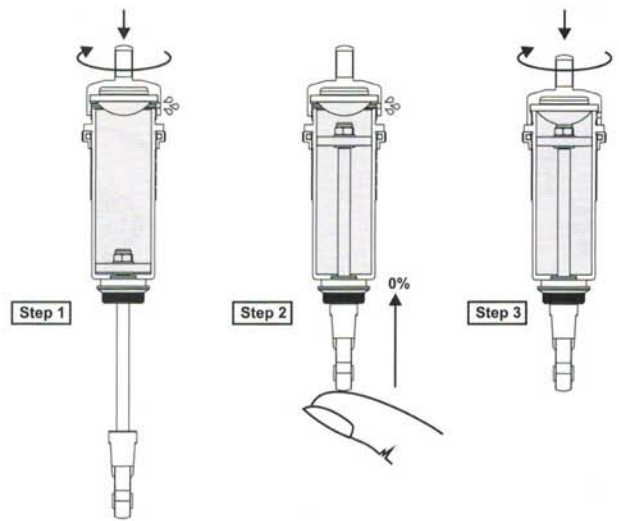

## 75 ASSEMBLY OF THE SHOCKS SPRING

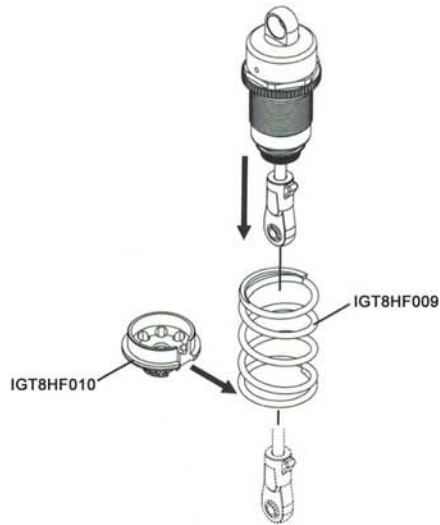

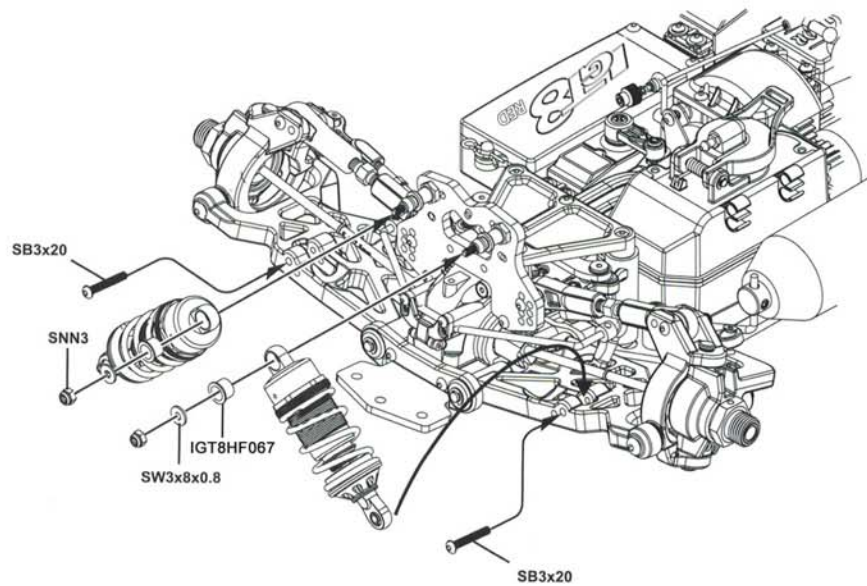
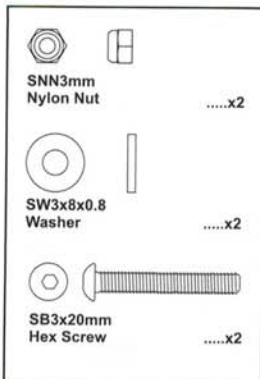

FRONT & REAR  
SHOCK

## 76 ASSEMBLY OF THE SHOCKS INTO THE SHOCK STAY

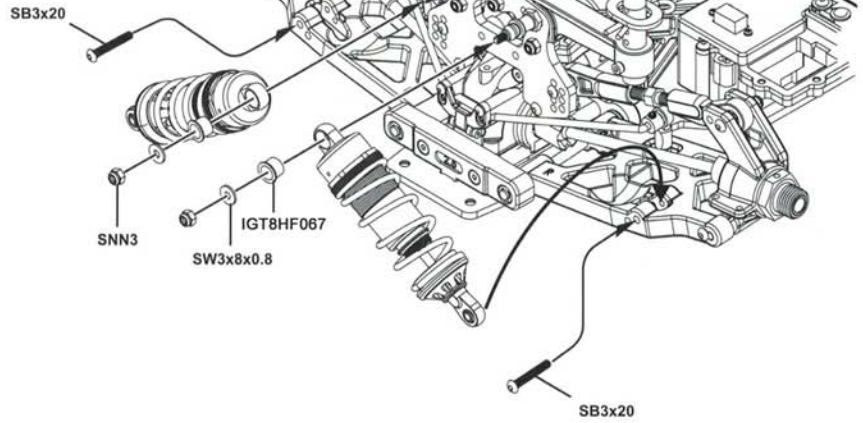

**77 ASSEMBLY OF THE SHOCKS INTO THE SHOCK STAY**

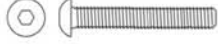

-  SNN3mm Nylon Nut .....x2
-  SW3x8x0.8 Washer .....x2
-  SB3x20mm Hex Screw .....x2

**78 ASSEMBLY OF THE FRONT BUMPER**

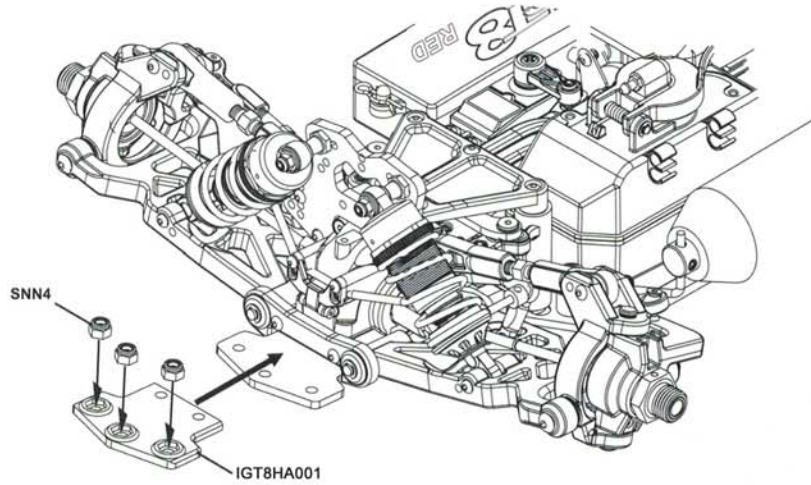

**BAG 8**

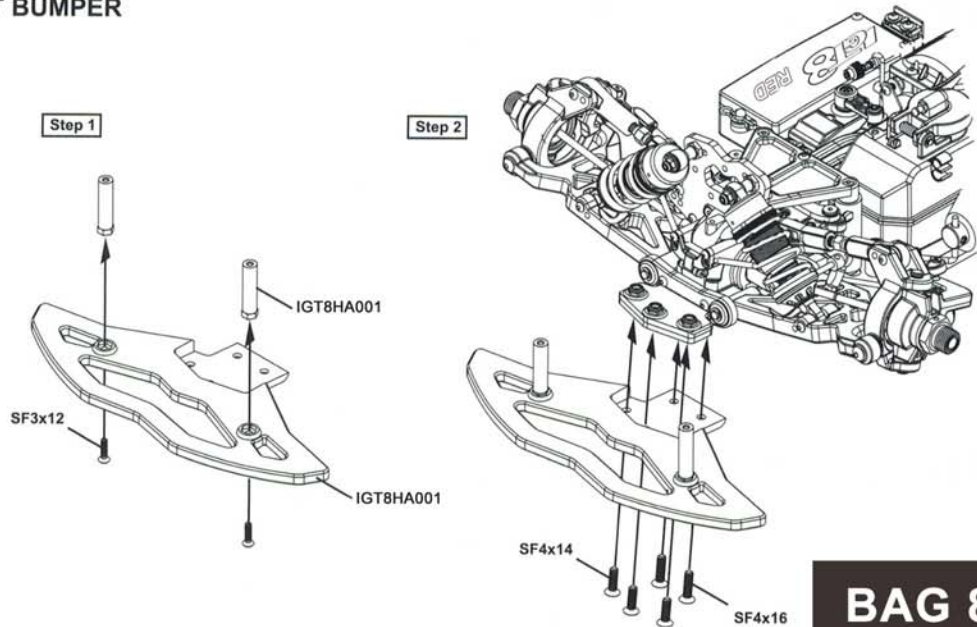

-  SNN4mm Nylon Nut .....x3

**79 ASSEMBLY OF THE FRONT BUMPER**



-  SF3x12mm Flat Head Hex Screw .....x2
-  SF4x14 Flat Head Hex Screw .....x3
-  SF4x16 Flat Head Hex Screw .....x2

**BAG 8**

## 80 ASSEMBLY OF THE FRONT BUMPER

### BAG 8

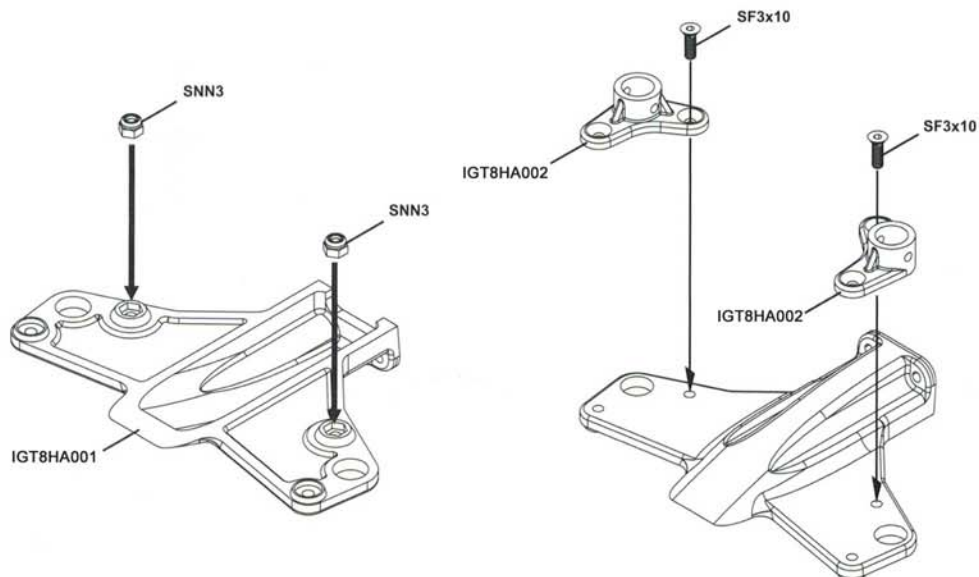

## 81 ASSEMBLY OF THE FRONT BUMPER

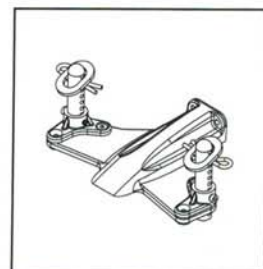
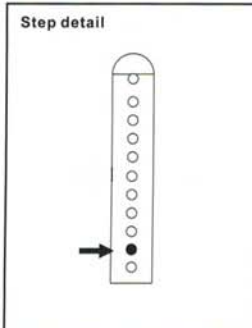
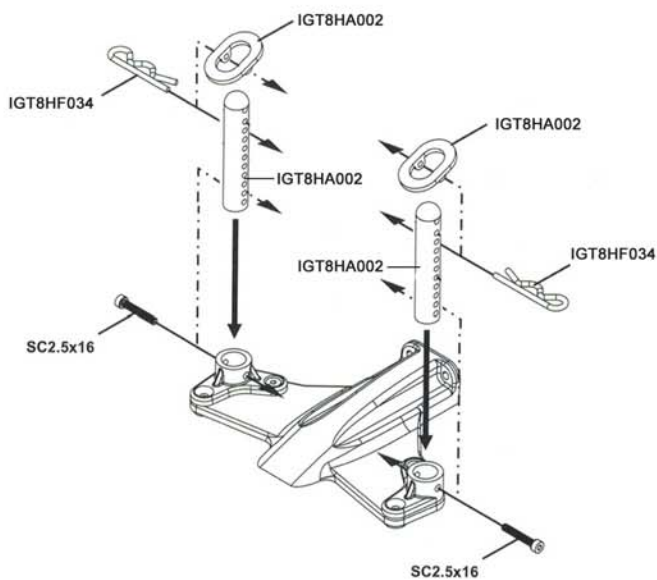
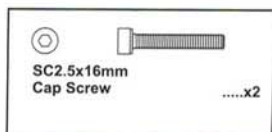

### BAG 8



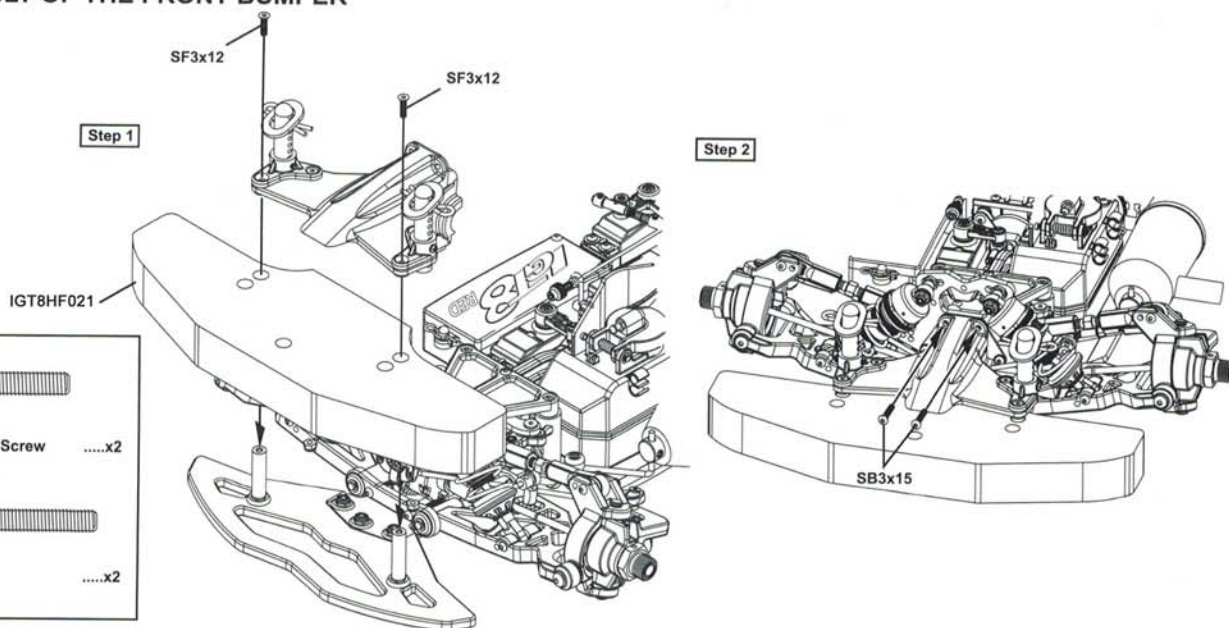
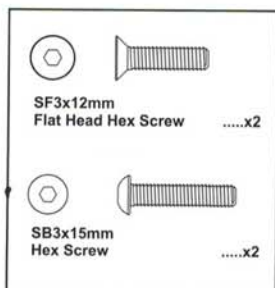



## 82 ASSEMBLY OF THE FRONT BUMPER



**BAG 8**

- 

SNN4mm Nylon Nut .....x2
- 

SF3x12mm Flat Head Hex Screw .....x2
- 

SF4x12mm Flat Head Hex Screw .....x2

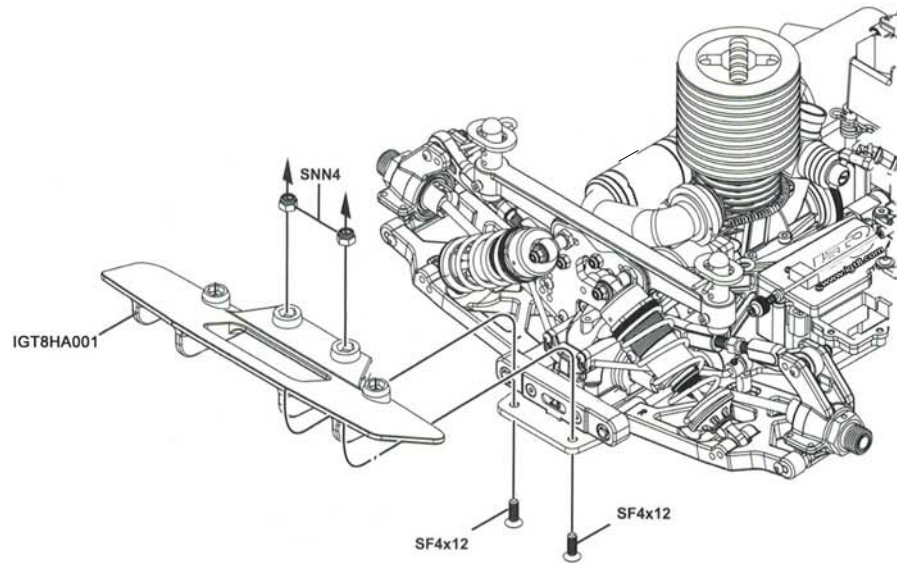

**BAG 7**

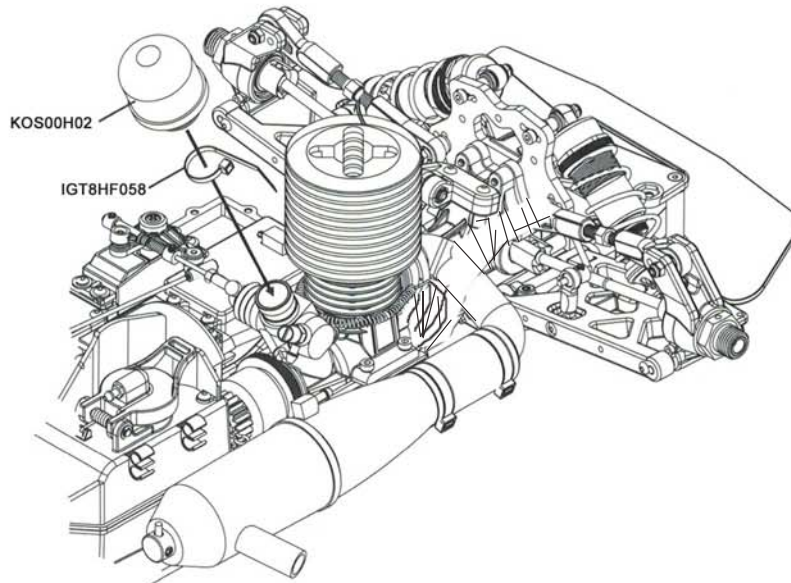

**BAG 7**

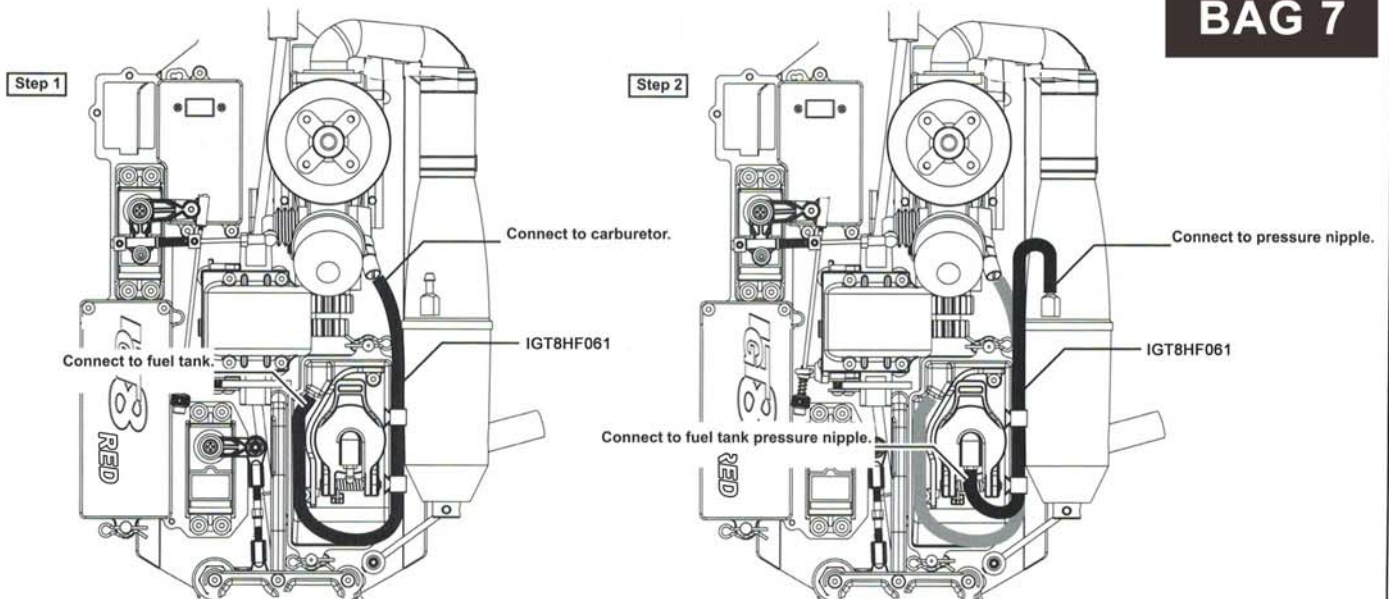

# SETTING GUIDE

## FRONT CAMBER ANGLE SETTING

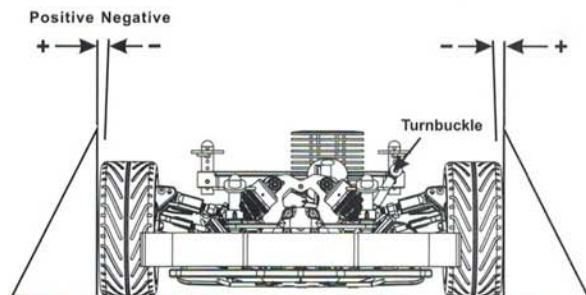

- Place the model car on flat surface. Raise the chassis to its maximum clearance before the wheels leave the ground.
- Adjust the length of the front and rear upper arms so that the wheels are vertical to the ground.
- Adjust the camber angle by turning the turnbuckle rod on the upper arms clockwise or anti-clockwise. (We suggest to use zero degree for the front and 1.5 degree negative for the rear.)

## REAR CAMBER ANGLE SETTING

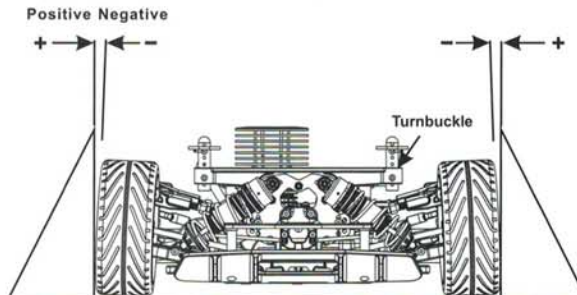

## FRONT TOE-IN AND TOE-OUT SETTING

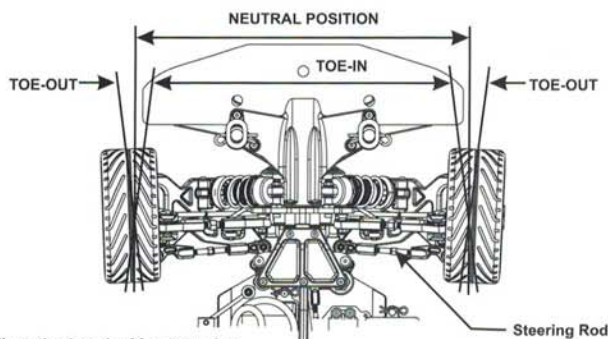

- Adjust the length of front steering rod to change the toe angle.
- Making the tie rod longer will make front tires toed in.
- Response will be slower and may over steer.
- Making the tie rod shorter will make front tires toed out.
- Response will be quicker and may under steer.

- Different shock positions will result in firmer or softer response of the suspension system.
- Install the shock in an inward angle will cause softer rebound. Softer or firmer suspension system will lead to different steering response.
- Adjust the shock angle positions according to track conditions.

## FRONT SHOCK ANGLE SETTING

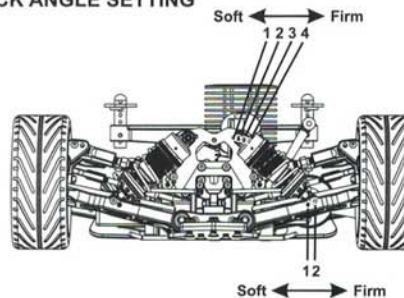

Firm front suspension, less steering.  
Soft front suspension, more steering.

## REAR WHEELBASE

Adjust the wheelbase by using the spacers on either side of the rear wheel hub (at the bottom pin). **IMPORTANT!** Make equal adjustments on both left and right sides of the car.

### Shorter wheelbase

- less spacers in front of the rear wheel hub.
- increases rearward weight transfer during acceleration.
- increases on-power traction.
- quicker off-power steering into corners.
- slight tendency to push on-power at corner exit.
- increases steering response.
- better on tighter, more technical tracks.

### Longer wheelbase

- more spacers in front of the rear wheel hub.
- decreases off-power steering into sharp corners.
- increases stability.
- slower initial steering reaction (off-power).
- improves on-power steering at corner exit.
- better handling over bumps and ruts.
- better on more open tracks with high-speed corners.

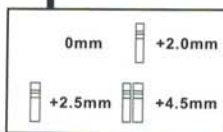
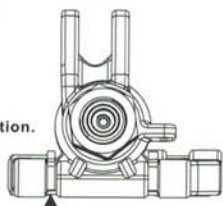

## REAR SHOCK ANGLE SETTING

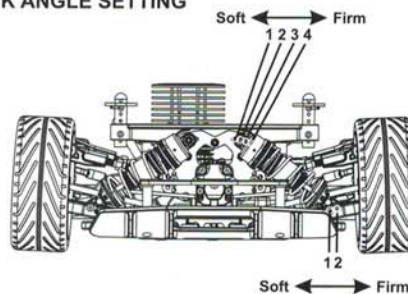

Firm rear suspension, over steering.  
Soft rear suspension, under steering.

## SHIFT UP TIMING ADJUSTMENT

- Once the engine adjustments have been completed, proceed to the adjustment of the clutch shoe shift timing. (Using a 2mm allen wrench to adjust the clutch shoe on either side.)

Note: Clockwise-----Shift timing will become slower.  
Anticlockwise---Shift timing will become quicker.

- Adjust the clutch shift timing for your track conditions. As you tighten (Clockwise) the 3x15mm screw, the shift timing will become slower. As you loosen (Anti-clockwise) the 3x15mm screw, the shift timing will become quicker.
- Set the shift timing to the track conditions while the car is running.

## 2 SPEED GEAR RATION COMBINATIONS

2 speed transmission allows the car to have more punch out of the corners and higher top speed. We offer many different pinion and spur gear combinations which can be used for different tracks.

Spur Gear	Clutch Gear (3 tooth different)			Torque
	15T-19T	16T-20T	17T-21T	
49T/45T	←-----→			Speed
48T/44T				

## ADJUSTING THE SHIFT POINT

- Adjust the engine before adjusting the clutch shift timing.
- Adjust the engine as per engine instruction manual.

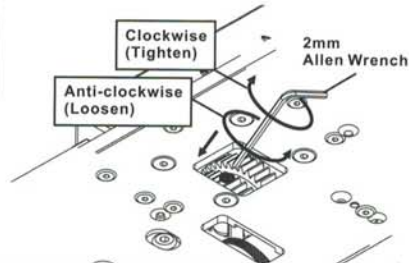
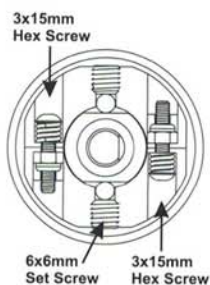

- \* Use a 2mm allen wrench to set the clutch shoe.
- \* Use a 2.5mm allen wrench to adjust the 6x6mm set screw which is used to adjust the distance between the clutch shoe and clutch bell.
- \* Adjust the 3x15mm hex screw will be change the shift timing of the clutch shoe.

## IGT8 GT Red Parts

Part No.	Description	Qty	Part No.	Description	Qty
IGT8HE001	13x20 Ball Bearing	4	IGT8HD020	Center CVD Universal Joint Set (F) 95mm	1
IGT8HF009	16mm GT Shock Spring Set 2.3mm	1	IGT8HD010	Center CVD Universal Joint Set (R) 105mm	1
IGT8HF020	16mm Pressure Top (orange)	4	IGT8HC001	Clutch Bell	1
IGT8HF008	16mm Shock Body	4	IGT8HC014	Clutch Gear (1st) 14T	1
IGT8HF012	16mm Shock Piston	8	IGT8HC018	Clutch Gear (2nd) 18T	1
IGT800H15	17mm Wheel Hub	2	IGT8HB001	Clutch Shoe	2
IGT8HF064	19x1.5mm O-Ring	4	IGT8HC008	Clutch Shoe Carrier	1
IGT8HC002	1st Spur Gear Holder	1	IGT800H14	CNC Front C Hub	1
IGT8HF036	2.5x11.8 Pins	10	IGT800H08	CNC Suspension Bracket	1 Set
IGT8HF070	2.5x12.8 Pins	10	IGT8HD004	CVD Wheel Axle	2
IGT8HF039	2.5x16.8 Pin	4	IGT8HF037	Diff Bell Gear Shim 13x16x0.2mm	4
IGT8HF083	2mm Adjust Nut	1	IGT8HF001	Diff Case (F&R)	1
IGT8HC003	2nd Spur Gear Clutch Bell	1	IGT8HF035	Diff Gasket 31x20x0.3	2
IGT8HC004	2-Speed Shaft	1	IGT8HF004	Diff Gear 10Tx4, 20Tx2	1 Set
IGT800224	3 Shoe GT Hybrid Adjustable Clutch System	1	IGT8HF071	Drive Shaft Insert / 2.5x12.8 Pin	4
IGT8HF019	3.5x45.8 Rear Hub Shaft	2	IGT800H20	Engine Mount	2
IGT8HF048	3x36mm Turnbuckle	2	IGT8HF021	Foam Bumper	1
IGT8HB046	46T 2nd Spur Gear	1	IGT8HA003	Front & Center Top Deck	1
IGT8HB049	49T 1st Spur Gear	1	IGT8HF078	Front Anti-Roll Bar 2.3mm	1
IGT8HF063	4mm Ball	2	IGT8HF042	Front Arm Bushing	4
IGT8HF027	4mm Cross Pin	2	IGT8HD04A	Front CVD Drive Shaft 107.5mm	2
IGT8HF046	4x10 Round Head Set Screw	4	IGT8HA004	Front Lower Arms L,R	1
IGT8HF028	4x46 Turnbuckle	4	IGT8HA001	Front/Rear Bumper	1
IGT8HF074	4x8mm Engine Mount Screws	4	IGT8HF060	Fuel Tank	1
IGT8HE008	5x11x4mm Ball Bearing	8	IGT800H23	Fuel Tank Post	2
IGT8HF023	5x35 Turnbuckle	2	IGT8HF061	Fuel Tube	1
IGT8HF045	6mm Ball	6	IGT8HF073	Hex 4mm Ball & Socket	2
IGT8HF047	6mm Ball & Socket	6	IGT8HF041	Knuckle Arm Bushing	4
IGT8HF063	6x6mm Set Screw	2	IGT8HF062	Muffler Stay	1
IGT8HF038	7mm Ball	6	IGT800H13	Muffler Stay Post	1
IGT8HF033	7x12mm Ball & Socket	4	IGT800F10	One-pice bulkhead with CNC insert and bearings	2
IGT8HF031	7x8.5mm Ball & Socket	4	IGT8HF006	P-6 O-Ring	2
IGT8HC005	8mm Cap Joint for Brake	2	IGT8HF003	Pinion Bevel Gear, 13T	1
IGT8HE005	8x12 Flange Bearing	2	IGT8HA007	Plastic Rod End	1
IGT8HE006	8x14 Ball Bearing	4	IGT8HF067	Plastic Shock Parts Set	1
IGT8HE004	8x16 Ball Bearing	8	IGT8HF010	Plastic Shock Spring Holder	1 Set
IGT800H18	Ackerman	1	IGT8HF026	Rear Anti-Roll Bar 2.8mm	1
KOS00H02	Air Filter with Foam	2	IGT8HD003	Rear Drive Shaft	2
IGT8HC007	Alum. Nut (Clockwise)	1	IGT8HD001	Rear Drive Shaft (98mm)	2
IGT8HC006	Alum. Nut (Counter-Clockwise)	1	IGT8HA014	Rear Hub L, R	1
IGT8HF014	Alum. Servo Saver Tube	1	IGT8HA005	Rear Lowe Arms L,R	1
IGT800H11	Alum. Stopper	3 pcs	IGT8HA009	Receiver/Battery Box	1
IGT800H16	Alum. Wheel Hub	2	IGT8HF011	Repair Kit for #387	1 Set
IGT8HF043	Alum. Wheel Nut	2	IGT8HF002	Ring Bevel Gear, 43T	1
IGT8HF069	Arms Holder, Plastic	1 Set	IGT800H10	Servo Saver Adjusting Nut	1 Set
IGT8HE002	Ball Bearing 5x8x2.5	1	IGT8HF030	Servo Saver Bushing	2
IGT8HE003	Bearing 5x10x4	2	IGT8HF024	Servo Saver Post	2
IGT8HF034	Body Clips	1 Set	IGT8HF029	Servo Saver Screws	2
IGT8HA002	Body Post	1	IGT8HA006	Servo Saver Set/ Front Top Deck	1
IGT8HA011	Body Post/ Center Brace	1	IGT8X3SS	Servo Saver Spring	1
IGT8HF018	Brake Cam	2	IGT8HF022	Shock Ball End Post	4
IGT8HF015	Brake Disk (Front)	1	IGT800H21	Shock Cap 16mm	4
IGT8HF016	Brake Disk (Rear)	1	IGT8HF013	Shock Shaft, 45mm	4
IGT8HF053	Brake Lever	1	IGT8HF063	Spring	2
IGT8HF055	Brake Link 1.8x95mm	1	IGT800H22	Spring Adjuster 16mm	4
IGT8HF052	Brake Pad Springs	8	IGT8HF044	Stabilizer Ball End	2
IGT8HF051	Brake Rod 2x68mm	3	IGT8HF040	Steering King Pin	4
IGT8HF054	Brake Rod Spring	2	IGT8HA013	Steering Knuckle Arm L,R	1
IGT8HF005	Cap Joint for Diff	2	IGT8HF056	Throttle Spring	2
IGT800F07	Carbon Fiber Front Shock Tower	1	IGT8HA010	Throttle/Steering Level Set	1
IGT800F08	Carbon Fiber Rear Shock Tower	1			